

PRZEKŁADKI STALOWE SPRZĘGŁA MOTOCYKLE OFF ROAD



PRZEKŁADKI STALOWE SPRZĘGŁA

Lucas



EBS
POWER & QUALITY

NEWFREN
Brake & Clutch Technology

Model	Rok	EBS		Lucas		Newfren		
		Kod	Cena	Kod	Cena	Kod	Szt.	Cena

GAS GAS

EC 125		98-08	P 005-6	84 zł	MES 326-7	159 zł	F.1634C	6	84 zł
MC 125		98-05	P 005-6	84 zł	MES 326-7	159 zł	F.1634C	6	84 zł
SM 125		01-08	P 005-6	84 zł	MES 326-7	159 zł	F.1634C	6	84 zł
EC/MC 200/250/300		00-08	P 004-7	105 zł					
EC/SM 450		03-08	P 005-6	84 zł	MES 326-7	159 zł	F.1364C	6	84 zł
EC/SM 515		05-08	P 004-7	105 zł					

HONDA

CR 80/85 R		85-07	P 028-4	52 zł	MES 331-4	94 zł	F.1623C	4	52 zł
CR 125 R		84-85	P 005-5	70 zł	MES 326-5	109 zł	F.1634C	5	70 zł
CR 125 R		85-99	P 005-6	84 zł	MES 326-6	139 zł	F.1634C	6	84 zł
CR 125 R		00-07	P 005-7	98 zł	MES 326-7	159 zł	F.1634C	7	98 zł
CRF 150R		06-09	P 120-4	52 zł					
CR 250 R		83-89	P 004-6	90 zł	MES 332-6	134 zł	F.1631C	6	90 zł
CR 250 R		90-93	P 004-7	105 zł	MES 332-8	179 zł	F.1684C	7	105 zł
CR 250 R		94-07	PS004C**	105 zł	MES 411-7	159 zł	F.1684C	7	105 zł
CRF 250 R/X		04-11	P 041-7	98 zł	MES 326-7	159 zł	F.1634C	7	98 zł
CRF 450 R		02-11	P 004-7	105 zł	MES 360-7	159 zł	F.1684C	7	105 zł
CRF 450 X		04-09	P 004-7	105 zł	MES 360-7	159 zł	F.1684C	7	105 zł
CR 500		84-89	P 004-6	90 zł	MES 332-6	134 zł			
CR 500		90-03	P 004-7	105 zł	MES 332-8	179 zł			
XR 650 R		00-07	P 004-6	90 zł	MES 332-6	134 zł			

** PS 004C = P 004-5 + P 076-2

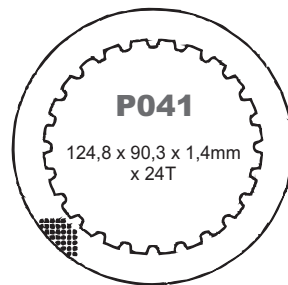
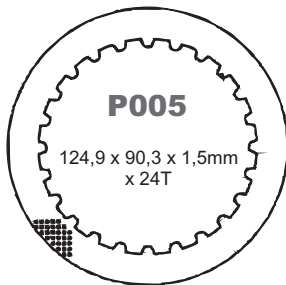

HUSQVARNA

CR/WR 125		94-08			MES 326-6	139 zł	F.1414C	6	90 zł
CR/WR 250		94-99					F.1415C	6	90 zł
CR/WR 250		00-09	P 004-7	105 zł			F.1417C	7	105 zł
CR/WR 360		94-99					F.1415C	6	90 zł
WR 360		00-09					F.1417C	7	105 zł
TE 410		-00					F.1417C	7	105 zł
TE 410		01-					F.1418C	6	90 zł
TE 570		01-					F.1418C	6	90 zł
TC 610		00-					F.1417C	7	105 zł

HUSABERG

FE 450		07-08			MES 357-8	179 zł			
FS 450		07-08			MES 357-8	179 zł			
FE 550		07-08			MES 357-8	179 zł			
FE 650		07-08			MES 357-8	179 zł			
FS 650		07-08			MES 357-8	179 zł			

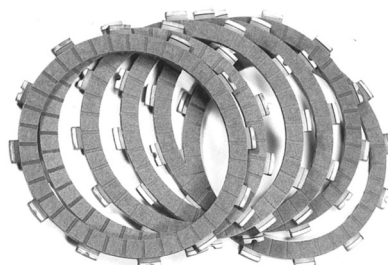

PRZEKŁADKI STALOWE SPRZĘGŁA MOTOCYKLE OFF ROAD



PRZEKŁADKI STALOWE SPRZĘGŁA



Model	Rok	EBS		Lucas		Newfren		
		Kod	Cena	Kod	Cena	Kod	Szt.	Cena

KAWASAKI

KX 60		83-03	P 030-4	52 zł				F.1750C	4	52 zł
KX 65		00-11	P 030-4	52 zł				F.1750C	4	52 zł
KX 80		88-97	P 030-6	78 zł				F.1742C	6	78 zł
KX 80/85		98-11	P 081-5	65 zł	MES 309-5	109 zł		F.1720C	5	65 zł
KX 125		86-93	P 032-7	98 zł	MES 349-7	159 zł				
KX 125		94-08	P 074-6	84 zł	MES 302-6	134 zł		F.1762C	6	90 zł
KX 250		87-91	P 035-7	105 zł	MES 306-7	159 zł		F.1764C	7	105 zł
KX 250		92-08	P 047-7	105 zł	MES 304-7	159 zł		F.1772C	7	105 zł
KXF 250		04-11	P 074-7	98 zł	MES 354-7	159 zł		F.1759C	7	105 zł
KLX 450 R		09-11	P 071-7	105 zł				F.1798C	7	105 zł
KXF 450		06-11	P 071-7	105 zł				F.1798C	7	105 zł
KX 500 D		88-04	P 035-7	105 zł	MES 306-7	159 zł		F.1764C	7	105 zł

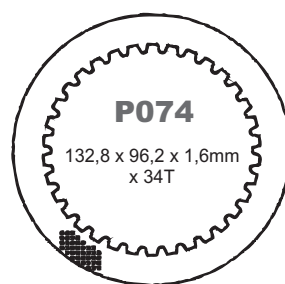
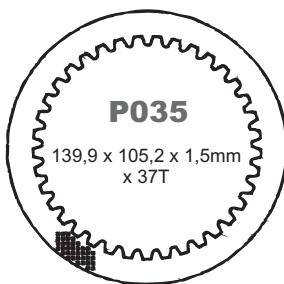
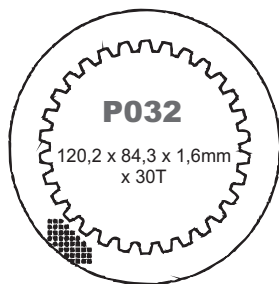

KTM

SX 60/65		98-	P 091-5	70 zł						
SX 85		03-10	P 115-6	84 zł				F.1511C	6	90 zł
GS/MX 125		74-83						F.1460C	1 szt.	19 zł
EXC/MX 125		84-97						F.1456C	1 szt.	20 zł
SX/EXC 125		98-10	P 005-6	84 zł				F.1502C	6	84 zł
SX 144		08-	P 005-6	84 zł				F.1502C	6	84 zł
SX 150		09-10	P 005-6	84 zł	MES 419-6	139 zł		F.1502C	6	84 zł
SX/EXC 200		03-10	P 005-6	84 zł	MES 419-6	139 zł		F.1502C	6	84 zł
GS/MX 250		85-						F.1460C	1 szt.	19 zł
SX/EXC 250		90-10	P 085-8	120 zł	MES 350-8	189 zł		F.1503C	8	120 zł
EXC (4T) 250		01	P 111-8	120 zł				F.1504C	8	128 zł
EXC (4T) 250		02-03	PS 111A*	120 zł				F.1501C	8	128 zł
EXC (4T) 250		04-06	P 111-8	120 zł				F.1507C	8	128 zł
SX-F 250		06-10	P 072-7	105 zł	MES 356-7	159 zł		F.2602C	7	105 zł
EXC-F 250		07-10	P 072-7	105 zł	MES 356-7	159 zł		F.2602C	7	105 zł
EXC 300		96-08	P 085-8	120 zł	MES 350-8	189 zł		F.1503C	8	120 zł
SX-F 350		09-								
SX/EXC 360		96-	P 085-8	120 zł	MES 350-8	189 zł		F.1503C	8	120 zł
SX/EXC 380		96-	P 085-8	120 zł	MES 350-8	189 zł		F.1503C	8	120 zł
SX/EXC 400		00-01	P 111-8	120 zł				F.1504C	8	128 zł
SX/EXC 400		02	PS 111A*	120 zł				F.1501C	8	128 zł
EXC 400		04-05	P 111-8	120 zł				F.1507C	8	128 zł
EXC 400		06-07	PS 111A*	120 zł				F.1501C	8	128 zł
SX/EXC 450		03	PS 111A* lub P 106-8	120 zł				F.1501C	8	128 zł
SX/EXC 450		04-05	P 111-8	120 zł				F.1507C	8	128 zł
SX 450		06	PS 111A*	120 zł				F.1501C	8	128 zł
EXC 450		06-07	PS 111A*	120 zł				F.1501C	8	128 zł
SX-F 450		07-08	P 054-8	120 zł	MES 357-8	179 zł		F.1513C	8	120 zł
EXC 450		08-	P 170-8	120 zł				F.1510C	8	120 zł
SXF 505		07-08	P 054-8	120 zł				F.1513C	8	120 zł
XCF 505		08	P 054-8	120 zł				F.1513C	8	120 zł
SX/EXC 520		00-01	P 111-8 lub P 106-8	120 zł				F.1504C	8	128 zł
SX/EXC 520		02	PS 111A* lub P 106-8	120 zł				F.1501C	8	128 zł

PRZEKŁADKI STALOWE SPRZĘGŁA MOTOCYKLE OFF ROAD



PRZEKŁADKI STALOWE SPRZĘGŁA

Lucas



Model	Rok	EBS		Lucas		Newfren		
		Kod	Cena	Kod	Cena	Kod	Szt.	Cena

KTM c.d.

SX/EXC	525	03	PS 111A* lub P 106-8	120 zł			F.1501C	8	128 zł
SX/EXC	525	04-05	P 111-8 lub P 106-8	120 zł			F.1507C	8	128 zł
SX	525	06	PS 111A*	120 zł			F.1501C	8	128 zł
EXC	525	06-07	PS 111A*	120 zł			F.1501C	8	128 zł
EXC/ EXC-R	530	08-	P 170-8	120 zł			F.1510C	8	120 zł
SXC	540	98-99	P 154-7	105 zł	MES 351-7	169 zł	F.1505C	7	105 zł

* PS 111A = P 111-4 + P 112-4

F.1501C = 4 x 3F.5280 + 4 x 3F.5281

F.1504C = 8 x 3F.5283

F.1507C = 8 x 3F.5281

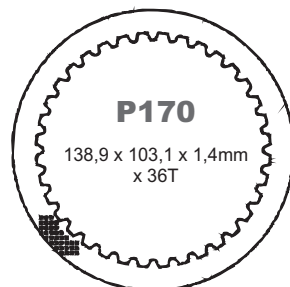
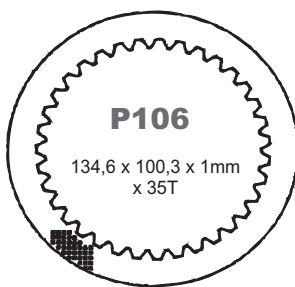
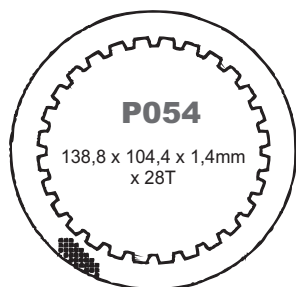

SUZUKI

RM	80	RC12A	86-01	P 039-4	52 zł	MES 345-4	94 zł	F.1980C	4	52 zł
RM	85		86-10	P 039-4	52 zł	MES 345-4	94 zł	F.1980C	4	52 zł
RM	125		88-91	P 025-7	98 zł			F.1974C	7	98 zł
RM	125		92-10	P 050-7	105 zł	MES 346-7	159 zł	F.1759C	7	105 zł
RM	250	RJ14A	88-91	P 036-7	105 zł	MES 337-8	179 zł	F.1990C	7	105 zł
RM	250	RJ14A	92-93	P 036-8	120 zł	MES 337-8	179 zł	F.1996C	8	120 zł
RM	250	RJ14A	94-95	P 036-7	105 zł	MES 337-8	179 zł	F.1996C	7	105 zł
RM	250	RJ17A	96-10	P 079-7	105 zł	MES 308-7	159 zł	F.1772C	7	105 zł
RM-Z	250		04-09	P 074-7	98 zł	MES 354-7	159 zł	F.1759C	7	105 zł
RM-Z	250		07-11			MES 354-7	159 zł			
RM-Z	450		05-11	P 133-7	105 zł	MES 416-7	159 zł			
RMX	450		09-11	P 133-7	105 zł	MES 416-7	159 zł			

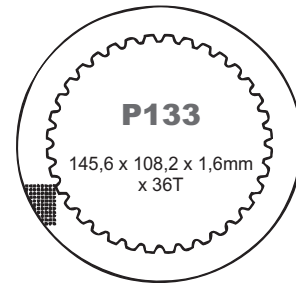
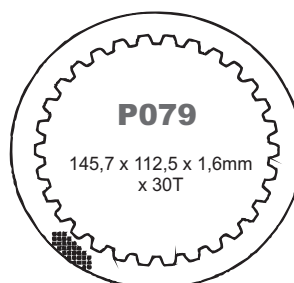
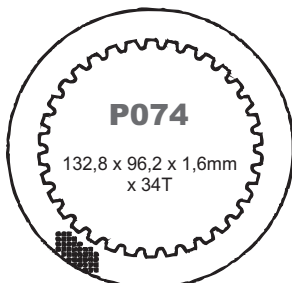
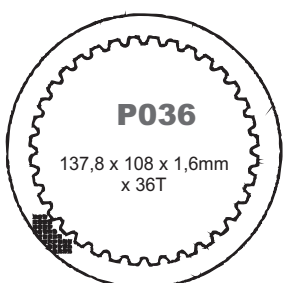

PRZEKŁADKI STALOWE SPRZĘGŁA MOTOCYKLE OFF ROAD



PRZEKŁADKI STALOWE SPRZĘGŁA

Model		Rok	EBS		Lucas		Newfren		
			Kod	Cena	Kod	Cena	Kod	Szt.	Cena
YZ	80	86-94	P 003-5	65 zł			F.2836C	5	65 zł
YZ	80	95-01	P 003-6	78 zł			F.2836C	6	78 zł
YZ	85	02-10	P 070-6	78 zł			F.2836C	6	78 zł
YZ	125	86-87	P 014-5	75 zł					
YZ	125	88-90	P 013-6	84 zł			F.1830C	6	84 zł
YZ	125	91-11	P 044-7	98 zł	MES 321-7	159 zł	F.2821C	7	98 zł
YZ	250	85-87			MES 325-6	134 zł			
YZ	250	88-92	P 038-6	90 zł	MES 352-6	134 zł	F.1856C	6	90 zł
YZ	250	93-10	P 038-7	105 zł	MES 352-6	134 zł	F.1864C	7	105 zł
YZF	250	01-11	P 099-8	112 zł			F.2846C	8	120 zł
YZF	400 F	98-99	P 061-7	105 zł			F.1852C	7	136 zł
WRF	400	98-01	P 061-7	105 zł			F.1852C	7	136 zł
YZF	426	00-02	P 089-8	120 zł					
WRF	426 F	00-02	P 089-8	120 zł	MES 318-7	159 zł	F.2844C	8	128 zł
WR	450 F	03-04	P 089-8	120 zł	MES 316-8	184 zł			
WR	450 F	05-10	P 038-7	105 zł	MES 316-8	184 zł			
YZF	450	03-06	P 089-8	120 zł					
YZF	450 FW	07-10			MES 316-8	184 zł	F.1864C	8	120 zł
YZ	490	82-88	P 008-6	96 zł					

PRZEKŁADKI STALOWE SPRZĘGŁA

A T V



Model		Rok	EBS		Lucas		Newfren		
			Kod	Cena	Kod	Cena	Kod	Szt.	Cena
TRX	90	93-09			MES 331-4	94 zł			
TRX	200 Fourtrax	90-97			MES 331-4	94 zł			
TRX	250 Recon	97-05	P 042-4	56 zł			F.1623C	4	56 zł
TRX	250 EX Sportrax	01-05	P 042-4	56 zł			F.1623C	4	56 zł
TRX	300 EX Fourtrax	88-05	P 041-5	75 zł	MES 310-5	109 zł	F.1633C	5	75 zł
TRX	350 TE, FE, Fourtrax Rancher	00-05	P 041-5	75 zł	MES 310-5	109 zł	F.1633C	5	75 zł
TRX	400 Fourtrax	99-04	P 053-6	90 zł	MES 334-6	134 zł			
TRX	400 Sportrax	01-06	P 053-6	90 zł	MES 334-6	134 zł			
TRX	420 Fourtrax	07-09	P 041-5	75 zł	MES 310-5	109 zł	F.1633C	5	75 zł
TRX	450 Fourtrax	99-03	P 041-5	75 zł	MES 310-5	109 zł	F.1633C	5	75 zł
TRX	450 R	03-05	P 076-7 (1,5mm) lub P 054-7 (1,4mm)	75 zł					
TRX	500 Fourtrax	05-09	P 041-6	90 zł	MES 310-6	139 zł	F.1633C	6	90 zł
TRX	700 XX	08-09	P 191-7	112 zł					

KAWASAKI

KSF	250	94-02					F.1762C	6	96 zł
KLF	250 Bayou	03-09	P 072-4	60 zł					
KEF	300 Lakota	95-03	P 075-4	64 zł					
KLF	300	86-05	P 075-4	64 zł					
KLF	400 Bayou	93-98	P 071-5	75 zł	MES 358-5	109 zł			
KFX	450 R	07-08	P 071-7	105 zł	MES 358-7	154 zł			



LUCAS

EBS
POWER & QUALITY

NEWFREN
Brake & Clutch Technology

PRZEKŁADKI STALOWE SPRZĘGŁA A T V



Model	Rok	EBS		Lucas		Newfren		
		Kod	Cena	Kod	Cena	Kod	Szt.	Cena

SUZUKI

LTF	160			89-04	P 025-6	84 zł						
LTZ	250	QuadSport		04-09	P 039-5	65 zł						
LT-F	300	Quadrunner		91-98	P 025-6	84 zł						
LT-F	300	Quadrunner		99-01	P 010-6	84 zł				F.1974C	6	84 zł
LT-F	300	King Quad		91-01	P 025-7							
LT-F	400	Eiger		02-08	P 075-5 (2mm) lub P 071-5 (1,6mm)	80 zł lub 75zł	MES 358-5 (1,6mm)	109 zł				
LTZ	400	QuadSport		03-04	P 071-7	105 zł	MES 358-7	154 zł				
LTZ	400	QuadSport		05	P 071-8	120 zł	MES 358-8	174 zł				
LTR	450			06-10	P 133-7	105 zł	MES 416-7	159 zł				
LT-F	500	Quadrunner		98-04	P 075-5 (2mm) lub P 071-5 (1,6mm)	80 zł lub 75zł	MES 358-5 (1,6mm)	109 zł				

YAMAHA

YFS	200	Blaster		88-06	P 046-6	90 zł	MES 317-6	134 zł				
YFB	250	Timberwolf		92-00	P 003-4	52 zł	MES 317-4	94 zł				
YFM	250	Bear Tracker		99-03	P 003-4	52 zł	MES 317-4	94 zł				
YFM	250	Raptor		08-09	P 044-5	70 zł						
YFM	350	Raptor		04-05	PS 008C*	96 zł						
YFM	350	Big Bear		87-93	PS 008C*	96 zł						
YFM	350	Warrior		87-04	PS 008C*	96 zł						
YFZ	350	Banshee		87-06	P 061-7	105 zł	MES 318-7	159 zł	F.1831C	7	119 zł	
YFM	400	Kodiak		93-99	PS 008C*	96 zł						
YFM	400	Big Bear		03-04	PS 008C*	96 zł						
YFZ	450			04-09	P 038-7	105 zł	MES 359-7	159 zł				
YFM	660	Raptor	AM01	01-06	P 061-7	105 zł	MES 318-7	159 zł	F.1867C	7	119 zł	
YFM	700	Raptor		06-10	P 038-7	105 zł	MES 359-7	159 zł	F.1892C	7	119 zł	

* P 008C = P 008-4 + P 043-2

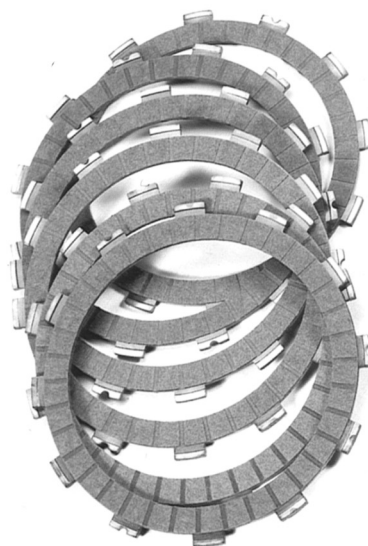

PRZEKŁADKI STALOWE SPRZĘGŁA

Lucas



POWER & QUALITY
EBS

NEWFREN
Brake & Clutch Technology

PRZEKŁADKI STALOWE SPRZĘGŁA M O T O C Y K L E



PRZEKŁADKI STALOWE SPRZĘGŁA



Model		Rok	EBS		Lucas		Newfren				
			Kod	Cena	Kod	Cena	Kod	Szt.	Cena		
APRILIA											
	50	Classic	GI	95-01	P 002-3	42 zł	MES 317-4	94 zł	F.1540C	3	42 zł
	50	Pegaso		92-94	P 002-3	42 zł	MES 317-4	94 zł	F.1540C	3	42 zł
	50	Red Rose		88-94	P 002-3	42 zł	MES 317-4	94 zł	F.1540C	3	42 zł
	50	Tuono		03-04	P 002-3	42 zł	MES 317-4	94 zł	F.1540C	3	42 zł
AF1	50	Futura		89-92	P 002-3	42 zł	MES 317-4	94 zł	F.1540C	3	42 zł
MX	50			03-05	P 002-3	42 zł	MES 317-4	94 zł	F.1540C	3	42 zł
RS	50	Extrema	HP	90-94	P 002-3	42 zł	MES 317-4	94 zł	F.1540C	3	42 zł
RS	50			93-05	P 002-3	42 zł	MES 317-4	94 zł	F.1540C	3	42 zł
RX	50			03-04	P 002-3	42 zł	MES 317-4	94 zł	F.1540C	3	42 zł
RS	125	(Rotax)		95-06					F.1411C	6	90 zł
	660	Pegaso Factory		07-08			MES 352-6	134 zł	F.1496C	6	90 zł
	660	Pegaso Strada		05-07			MES 352-6	134 zł	F.1496C	6	90 zł
	660	Pegaso Trail		05-08			MES 352-6	134 zł	F.1496C	6	90 zł
RSV/ SL	1000			97-07					F.1498C	10	140 zł
BETA											
RR	125			06-08			MES 317-4	94 zł			
	350	Alp 4.0		03-08	P 036-6	90 zł	MES 337-6	134 zł	F.1988C	6	90 zł
CAGIVA											
	125	Mito		91-					F.1591C	6	90 zł
	1000	Navigator		00-05			MES 353-8	179 zł			
	1000	Raptor		00-05			MES 353-8	179 zł			
	1000	Xtra-Raptor		02-05			MES 353-8	179 zł			
HARLEY-DAVIDSON											
		Big Twin		85-89	P 063-7	112 zł					
		Big Twin		90-97	P 086-8	128 zł					
		Big Twin		98-	P 090-8	128 zł					
		Sportster		91-	P 086-8	128 zł					
HONDA											
CA	125	Rebel	JC24/JC26	95-00			MES 331-4	94 zł	F.1623C	4	56 zł
CBR	125			04-10			MES 331-4	94 zł	F.1623C	4	56 zł
CG	125			01-08			MES 331-4	94 zł	F.1623C	4	56 zł
CLR	125	Cityfly	JD18B	98-99			MES 331-4	94 zł	F.1623C	4	56 zł
MTX	125	RW		85-91	P 005-4	56 zł	MES 326-4	94 zł			
NSR	125	R	JC22	88-03	P 005-5	70 zł	MES 326-5	109 zł			
NX	125			89-97	P 028-4	56 zł	MES 331-4	94 zł	F.1623C	4	56 zł
VT	125	Shadow	JC29	99-08			MES 336-4	94 zł			
XLR	125		JD	98-99	P 028-4	56 zł	MES 331-4	94 zł	F.1623C	4	56 zł
XLV	125	Varadero	JC32	01-10			MES 336-4	94 zł			
XR	125			03-08	P 028-4	56 zł	MES 331-4	94 zł	F.1623C	4	56 zł
MTX	200	RW	MD07	85-	P 005-4	56 zł	MES 326-4	94 zł			
MTX	200	RW	MD07	83-84	P 005-5	70 zł	MES 326-5	109 zł	F.1633C	5	75 zł
CBF	250			04-06	P 041-5	75 zł	MES 326-5	109 zł	F.1633C	5	75 zł
NX	250	Dominator	MD21	88-93	P 041-5	75 zł	MES 326-5	109 zł	F.1633C	5	75 zł
XL	250	R	MD11	84-87	P 041-4	60 zł	MES 326-4	94 zł			
XL	250	R	MD03	81-83			MES 336-4	94 zł			
XR	250	R		86-04	P 041-5	75 zł	MES 326-5	109 zł	F.1633C	5	75 zł
XL	350	R	ND03	85-87	P 041-5	75 zł	MES 326-5	109 zł	F.1633C	5	75 zł
CB	400	N	CB400N	79-82			MES 334-6	134 zł			
CB	400	T,T2	CB400T	78-82	P 005-6	84 zł	MES 326-6	139 zł			
CM	400	T	NC01	79-82	P 005-6	84 zł	MES 326-6	139 zł			
XR	400			97-05	P 041-6	90 zł	MES 326-6	139 zł			
CB	450	N	PC14	85-	P 005-6	84 zł	MES 326-6	139 zł			
CB	450	S	PC17	86-89	P 053-6	90 zł	MES 334-6	134 zł			
CB	450	SC	PC17	85-	P 005-6	84 zł	MES 326-6	139 zł			
CMX	450	Rebel	PC14	86-87	P 005-6	84 zł	MES 326-6	139 zł			

PRZEKŁADKI STALOWE SPRZĘGŁA M O T O C Y K L E



PRZEKŁADKI STALOWE SPRZĘGŁA

Lucas



POWER & QUALITY

EBS
NEWFREN
Brake & Clutch Technology

Model		Rok	EBS		Lucas		Newfren			
			Kod	Cena	Kod	Cena	Kod	Szt.	Cena	
CB	500	PC26	94-03	P 053-6	90 zł	MES 334-6	134 zł			
CBF	500		04-07	P 053-6	90 zł	MES 334-6	134 zł			
VT	500	PC08	83-86			MES 336-7	159 zł			
XBR	500	PC15	85-90			MES 332-6	134 zł			
XL	500	PD01	79-81	P 005-6	84 zł	MES 326-6	139 zł			
CB	600	Hornet	98-01	P 177-8	128 zł	MES 343-8	179 zł			
CB	600	Hornet	02-09	P 177-8	128 zł	MES 343-8	179 zł			
CB	600	Hornet	07-10			MES 361-7	tel.			
CBF	600	PC38	04-07	P 177-8	128 zł	MES 343-8	179 zł			
CBR	600	RR	03-10	P 165-7	112 zł	MES 330-7	159 zł			
CBR	600	F	PC19/PC23	87-90		MES 333-5	109 zł			
CBR	600	F	PC25	91-94	P 177-8	128 zł	MES 343-8	179 zł		
CBR	600	F	PC31	95-98	P 177-8	128 zł	MES 343-8	179 zł		
CBR	600	F	PC35	99-00	P 177-8	128 zł	MES 343-8	179 zł		
CBR	600	F	PC35	01-06	P 165-7	112 zł	MES 330-7	159 zł		
VT	600	C Shadow	PC21	88-90	P 005-6	84 zł	MES 326-6	139 zł		
VT	600	C Shadow	PC21	91-00	P 053-6	90 zł	MES 334-6	134 zł		
XL	600	LM	PD04	85-86	P 054-6	90 zł	MES 332-6	134 zł	F.1631C	6 90 zł
XL	600	R	PD03	83-87	P 054-6	90 zł	MES 332-6	134 zł	F.1631C	6 90 zł
XL	600	V Transalp	PD06	87-88			MES 336-7	159 zł		
XL	600	V Transalp	PD06	89-99	P 053-6	90 zł	MES 334-6	134 zł		
XR	600	R	PE04	85-00	P 054-6	90 zł	MES 332-6	134 zł		
CX	650	E						F.1631C	6 90 zł	
FMX	650		RD12	05-08	P 054-6	90 zł	MES 332-6	134 zł	F.1631C	6 90 zł
FX	650	Vigor	RD09	99-03	P 054-6	90 zł	MES 332-6	134 zł	F.1631C	6 90 zł
NTV	650	Deauville	RC47	98-05			MES 336-7	159 zł		
NTV	650	Revere	RC33	88-97			MES 336-7	159 zł		
NX	650	Dominator	RD02/RD08	88-02	P 054-6	90 zł	MES 332-6	134 zł	F.1631C	6 90 zł
SLR	650		RD09	97-98	P 054-6	90 zł	MES 332-6	134 zł	F.1631C	6 90 zł
XL	650	V Transalp	RD10	00-07			MES 336-7	159 zł		
XR	650	L		93-07	P 054-6	90 zł	MES 332-6	134 zł	F.1631C	6 90 zł
XR	650	R	RE01	01-07	P 054-6	90 zł	MES 332-6	134 zł	F.1631C	6 90 zł
XR	650	Africa Twin	RD03	88-90			MES 336-7	159 zł		
NT	700	Deauville		06-09			MES 336-7	159 zł		
XL	700	V Transalp		08-10			MES 336-7	159 zł		
CB	750	Seven Fifty		91-03						
CBX	750	F	RC17	84-86			MES 329-5	109 zł		
VF	750	C Magna	RC09	82-84			MES 329-5	109 zł		
VF	750	S	RC07	82-87			MES 329-5	109 zł		
VF	750	F	RC15	83-87			MES 329-6	134 zł		
VF	750	C Magna	RC43	93-00	P 177-8	128 zł	MES 343-8	179 zł		
VFR	750	F	RC24	86-89	P 177-8	128 zł	MES 343-8	179 zł		
VFR	750	F	RC36	90-99	P 177-8	128 zł	MES 343-8	179 zł		
VT	750	DC Black Widow	RC48	00-04			MES 336-7	159 zł		
VT	750	DC Shadow Spirit		07-10			MES 336-7	159 zł		
VT	750	C Shadow	RC44	97-08			MES 336-7	159 zł		

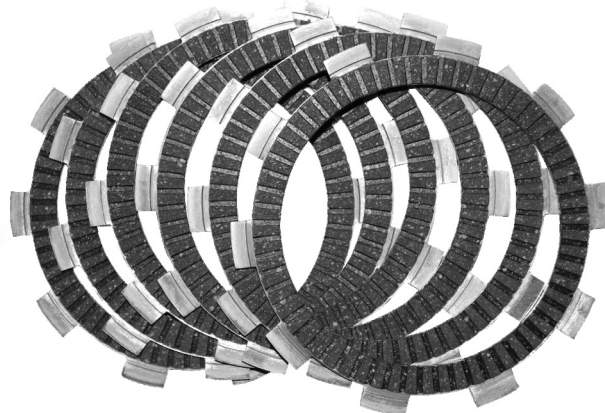

PRZEKŁADKI STALOWE SPRZĘGŁA M O T O C Y K L E



PRZEKŁADKI STALOWE SPRZĘGŁA

Model			Rok	EBS		Lucas		Newfren		
				Kod	Cena	Kod	Cena	Kod	Szt.	Cena
HONDA c.d.										
VFR	800		RC46	98-99	P 177-8	128 zł	MES 343-8	179 zł		
VFR	800		RC46	00-09	P 165-7	112 zł	MES 330-7	159 zł		
CB	900	Hornet	SC48	02-07	P 165-7	112 zł	MES 330-7	159 zł		
CBR	900	RR	SC28	92-95			MES 327-8	179 zł		
CBR	900	RR	SC33D	96-99	P 177-7	112 zł	MES 330-7	159 zł		
CBR	900	(929)RR	SC44	00-01			MES 327-8	179 zł		
CBR	954	RR	SC50	02-03			MES 327-8	179 zł		
CB	1000	R		09-10			MES 362-7	tel.		
CB	1000	Super Four	SC30	93-95			MES 333-8	179 zł		
CBR	1000	F	SC21/SC24	87-99			MES 333-8	179 zł		
CBR	1000	RR		05-07	P 178-6	102 zł				
GL	1000			76-79			MES 329-6	134 zł		
VTR	1000	Firestorm	SC36	97-05	P 191-9	144 zł	MES 335-9	199 zł		
VTR	1000	SP-1/SP-2	SC45	00-07			MES 328-6	134 zł		
XL	1000	Varadero	SD01,SD02	99-02	P 191-9	144 zł	MES 335-9	199 zł		
XL	1000	Varadero		03-09	P 191-7	112 zł	MES 335-7	159 zł		
CB	1100	SF (X-11)	SC42	00-03			MES 328-6	134 zł		
CBR	1100	XX	SC35	97-08			MES 328-8	179 zł		
ST	1100	Pan European	SC26	90-01	P 191-7	112 zł	MES 335-9	199 zł		
VT	1100	C2	SC32	95-99			MES 333-8	179 zł		
VT	1100	C3	SC39	98-02			MES 333-8	179 zł		
VT	1100	C	SC23	85-89			MES 329-5	109 zł		
VT	1100	Shadow	SC23	92-96			MES 329-5	109 zł		
CB	1300		SC54	03-09	P 191-7	112 zł	MES 335-7	159 zł		
ST	1300	Pan European		02-10			MES 355-7	179 zł		
VTX	1300		SC52	03-08			MES 355-7	179 zł		
GL	1800	Goldwing		01-10			MES 328-7	159 zł		
VTX	1800			01-08			MES 328-7	159 zł		

KAWASAKI

KMX	125		MX125B	95-03			MES 309-5	109 zł		
KDX	200			89-05	P 032-7	98 zł			F.1787C	7 98 zł
KDX	200			95-07	P 072-7	105 zł				
KDX	220			95-07	P 072-7	105 zł				
EL	250	Eliminator	EL250B	88-95			MES 303-5	109 zł		
KLR	250			84-05	P 059-5	75 zł				
KLX	250	S		09-11	P 032-6	84 zł				
EL	252	F	EL250F	96-03	P 055-5	75 zł	MES 303-5	109 zł		
KLX	300	R		97-07					F.1757C	7 90 zł
GPZ	400		KZ400M	83-89	P 055-6	90 zł	MES 303-6	139 zł		
Z	400		KZ400J	80-82	P 055-6	90 zł	MES 303-6	139 zł		
Z	400	F	ZR400B	84-	P 055-6	90 zł	MES 303-6	139 zł		
Z	440		KZ440D/H	82-84	P 055-5	75 zł	MES 303-5	109 zł		
Z	440	LTD	KZ440A	80-83	P 055-5	75 zł	MES 303-5	109 zł		
Z	450	LTD	EN450A	84-89	P 055-6	90 zł	MES 303-6	139 zł	F.1752C	6 90 zł
EN	500	Vulcan	EN500A	90-03	P 055-6	90 zł	MES 303-6	139 zł	F.1752C	6 90 zł
ER-5	500	Twister	ER500A/B/C/D	97-07	P 055-6	90 zł	MES 303-6	139 zł	F.1752C	6 90 zł
GPZ	500	S	EX500A	87-03	P 055-6	90 zł	MES 303-6	139 zł	F.1752C	6 90 zł
KLE	500		LE500A	91-07	P 055-6	90 zł	MES 303-6	139 zł	F.1752C	6 90 zł
GPZ	550		ZX550A	84-89	P 055-6	90 zł	MES 303-6	139 zł	F.1752C	6 90 zł
GT	550		KZ500G	83-90	P 055-6	90 zł	MES 303-6	139 zł	F.1752C	6 90 zł
Z	550	B/F	KZ550B	81-	P 055-6	90 zł	MES 303-6	139 zł	F.1752C	6 90 zł
ZR	550	Zephyr	ZR550B	91-96	P 055-6	90 zł	MES 303-6	139 zł	F.1752C	6 90 zł
GPX	600	R	ZX600C	88-00	P 055-6	90 zł	MES 303-6	139 zł	F.1752C	6 90 zł
GPZ	600	R	ZX600A	85-89	P 055-6	90 zł	MES 303-6	139 zł	F.1752C	6 90 zł
KLR	600		KL600B	84-93	P 055-6	90 zł	MES 303-6	139 zł	F.1752C	6 90 zł
ZL	600	Eliminator	ZL600A/B	85-97	P 055-6	90 zł	MES 303-6	139 zł	F.1752C	6 90 zł
ZX-6R	600	Ninja	ZX600F	95-97	P 190-9	135 zł	MES 310-9	179 zł		
ZX-6R	600	Ninja	ZX600G	98-99	P 190-9	135 zł	MES 310-9	209 zł		

PRZEKŁADKI STALOWE SPRZĘGŁA M O T O C Y K L E



PRZEKŁADKI STALOWE SPRZĘGŁA

Lucas



Model			Rok	EBS		Lucas		Newfren			
				Kod	Cena	Kod	Cena	Kod	Szt.	Cena	
KAWASAKI c.d.											
ZZR	600		ZX600D/E	90-07	P 055-6	90 zł	MES 305-6	134 zł	F.1752C	6	90 zł
ER6	650	N/F		06-10	P 055-6	90 zł			F.1752C	6	90 zł
KLE	650	Versys		06-10	P 055-6	90 zł			F.1752C	6	90 zł
KLR	650	A	KL650A	87-92	P 055-6	90 zł	MES 303-6	139 zł	F.1752C	6	90 zł
KLR	650	C	KL650C	95-05	P 055-7	105 zł	MES 303-7	159 zł			
KLX	650	C	KLX650C	93-99	P 055-6	90 zł	MES 303-6	139 zł			
W	650		EJ650A1	99-05			MES 304-7	159 zł	F.1772C	7	105 zł
GPX	750	R	ZX750F	85-89			MES 304-7	159 zł	F.1772C	7	105 zł
VN	750	Vulcan	VN750A	86-95			MES 304-7	159 zł	F.1772C	7	105 zł
Z	750	LTD	KZ750Y	82-83			MES 304-7	159 zł	F.1772C	7	105 zł
ZX-7R	750	Ninja	ZX750P	96-01							
ZXR	750	J/L	ZX750J/L	91-95							
VN	800		VN800A/B	95-05			MES 304-7	159 zł	F.1772C	7	105 zł
VN	800		VN800C	01-04			MES 308-7	159 zł			
GPZ	900	R	ZX900A	84-91			MES 304-7	159 zł	F.1772C	7	105 zł
VN	900	Classic		06-11			MES 304-7	159 zł	F.1772C	7	105 zł
VN	900	Custom		07-11			MES 304-7	159 zł	F.1772C	7	105 zł
ZX-9R	900	Ninja	ZX900D/E/F1/H	00-04	P 190-9	135 zł	MES 310-9	209 zł			
GPZ	1000	RX	ZXT00A	86-89			MES 305-8	179 zł			
GTR	1000		ZGT00A	86-03			MES 305-8	179 zł			
KLV	1000		LV1000A	04-05			MES 410-9	199 zł			
Z	1000		ZRT00A	03-10	P 190-9	135 zł	MES 310-9	209 zł			
ZX-10	1000	R	ZXT00C, D, E	04-10	P 190-9	135 zł	MES 310-9	209 zł			
GPZ	1100		KZT10B	81-85			MES 305-8	179 zł			
GPZ	1100	Horizont	ZXT10E	95-98	P 185-8	128 zł	MES 311-8	179 zł			
ZR	1100	Zephyr	ZRT10A/B	92-97			MES 305-8	179 zł			
ZRX	1100		ZRT10C	97-00			MES 305-8	179 zł			
ZZR	1100		ZXT10C, D, G	90-01	P 185-8	128 zł	MES 311-8	179 zł			
ZRX	1200		ZRT20A	01-08			MES 305-8	179 zł			
ZX-12R	1200		ZXT20A	01-07			MES 312-11	239 zł			
ZZR	1200		ZX1200C	02-05	P 185-8	128 zł	MES 311-8	179 zł			
ZZR	1400			08-11							

KTM

400	LC4			98-99	P 154-7	105 zł	MES 351-7	169 zł	F.1506C	7	105 zł
400	SC			96-97	P 154-7	105 zł	MES 351-7	169 zł			
625	SXC/SMC			02-06	P 154-7	105 zł	MES 351-7	169 zł			
625	640 Duke II			99-05	P 154-7	105 zł	MES 351-7	169 zł			
625	640 LC4 Advent			02-06	P 154-7	105 zł	MES 351-7	169 zł			
625	640 LC4 SM			02-	P 154-7	105 zł	MES 351-7	169 zł			
660	SMC			02-05	P 154-7	105 zł	MES 351-7	169 zł			
690	Duke			08-09	P 174-7	112 zł					
690	SM			07-09	P 174-7	112 zł					
690	Enduro			08-09	P 174-7	112 zł					
950	LC8 Adventure			03-06	P 158-10	150 zł			F.1515C	10	160 zł
950	LC8 Superenduro			07-08	P 158-10	150 zł			F.1515C	10	160 zł

RIEJU

50	Matrix			06-07			MES 317-4	94 zł			
50	RS 2			06-07			MES 317-4	94 zł			
MRX	125			06-07			MES 317-4	94 zł			
SMX	125			06-07			MES 317-4	94 zł			
125	Apache			02-03			MES 317-6	134 zł			
125	Tango			06-07			MES 317-4	94 zł			
125	RS 2			06-07			MES 317-4	94 zł			

PRZEKŁADKI STALOWE SPRZĘGŁA M O T O C Y K L E



PRZEKŁADKI STALOWE SPRZĘGŁA



Model			Rok	EBS		Lucas		Newfren			
				Kod	Cena	Kod	Cena	Kod	Szt.	Cena	
SUZUKI											
DR	125	S	SF42A	82-94			MES 345-4	94 zł	F.1980C	4	52 zł
DR	125	S	SF44A	99-01			MES 345-4	94 zł	F.1980C	4	52 zł
GN	125		NF41A	82-97			MES 347-4	94 zł	F.1980C	4	52 zł
GZ	125	Marauder	A	98-07			MES 347-4	94 zł	F.1980C	4	52 zł
RV	125	Van Van	WVBT	03-09			MES 347-4	94 zł	F.1980C	4	52 zł
VL	125	Intruder LC		99-08			MES 301-4	94 zł			
GN	250		NJ42A	84-99			MES 301-4	94 zł			
GZ	250	Marauder	AR	99-04			MES 301-4	94 zł			
DR	350	S/SE	SK42B	90-99	P 036-6	90 zł	MES 337-6	134 zł	F.1988C	6	90 zł
DRZ	400			00-09	P 071-7	105 zł					
GN	400	T,TD,L	GN400	80-81	P 036-6	90 zł	MES 337-6	134 zł	F.1988C	6	90 zł
GSX	400	E, L, S, F	GS40X	80-87	P 036-6	90 zł	MES 337-6	134 zł	F.1988C	6	90 zł
GS	450	E,S,L	GS450	80-88	P 036-6	90 zł	MES 337-6	134 zł	F.1988C	6	90 zł
GS	500	E, EU, F	GM51B	89-07			MES 337-6	134 zł	F.1988C	6	90 zł
GS	550	E, L, M, T	ALL	80-83			MES 337-6	134 zł			
DR	600	R,RU,S,SU	ALL	85-89			MES 301-6	139 zł			
GSF	600	Bandit	GN77B	94-04			MES 344-7	159 zł	F.1971C	7	119 zł
GSR	600		WVB9	06-10			MES 408-8	179 zł			
GSX	600	F	GN72B	88-91			MES 344-7	159 zł	F.1971C	7	119 zł
GSX	600	F	AJ	98-01			MES 344-7	159 zł	F.1971C	7	119 zł
GSX	600		GN72B	92-97	P 187-9	135 zł	MES 341-9	199 zł			
GSXR	600		AD	97-98			MES 414-9	199 zł			
GSXR	600		AD	99-00			MES 409-8	179 zł			
GSXR	600		WVBG	01-05			MES 408-8	179 zł			
GSXR	600		WVCE	06-07	P 182-6 P 181-1	112 zł	MES 356-7	179 zł			
GSXR	600			08-11			MES 415-8	179 zł			
VS	600	Intruder	VN51B	94-97			MES 301-6	139 zł			
DL	650	V-Strom	WVB1	04-10			MES 337-6	134 zł			
DR	650	R,RS,RE,RSE	SP44B	90-95	P 056-6	90 zł	MES 301-6	139 zł			
DR	650	SE	SP46B	96-99	P 078-7	128 zł	MES 412-8	179 zł	F.1969C	8	128 zł
GS	650	G	GS650G	81-82			MES 338-8	179 zł			
GSF	650	Bandit	WVB5	05-06			MES 344-7	159 zł	F.1971C	7	119 zł
GSF	650	Bandit	WVCJ	07-10			MES 417-7	159 zł			
GSX	650	F	WVCJ	08-10			MES 417-7	159 zł			
LS	650	Savage	NP41B	86-00			MES 301-6	139 zł			
SV	650	all models		99-10			MES 337-6	134 zł			
SVF	650	Gladius		09-10			MES 337-6	134 zł			
XF	650	Freewind	AC	97-01	P 078-7	128 zł	MES 412-8	179 zł	F.1969C	8	128 zł
DR	750	S,SU	SR41B	88-89			MES 412-8	179 zł	F.1969C	8	128 zł
GSX	750	ES, EF	GR72A	83-88			MES 338-8	179 zł			
GSX	750	F	AK	98-06			MES 344-7	159 zł			
GSX	750	F	G78A	89-97	P 187-9	135 zł	MES 341-9	199 zł			
GSX	750		AE	98-01			MES 344-7	159 zł			
GSXR	750		GR75A	85-87			MES 344-7	159 zł	F.1971C	7	119 zł
GSXR	750		GR77B	88-89	P 187-9	135 zł	MES 341-9	199 zł			
GSXR	750		GR7AB	90-91	P 187-9	135 zł	MES 341-9	199 zł			
GSXR	750	W	GR7BB	92-95	P 188-8	135 zł	MES 348-8	179 zł			
GSXR	750	W	GR7BB/DB	96-99	P 177-9	144 zł	MES 414-9	199 zł			
GSXR	750	W	WVBD,WVB3	00-05			MES 413-9	209 zł			
GSXR	750			06-10			MES 415-8	179 zł			
VS	750	Intruder	VR51BD	85-91			MES 301-6	139 zł			
DR	800	Big	all	90-97			MES 412-8	179 zł	F.1969C	8	128 zł
M	800	Intruder		05-08			MES 301-6	139 zł			
VL	800	C	WVBM	01-09			MES 301-6	139 zł			
VS	800	Intruder	VS52B	92-00			MES 301-6	139 zł			
VX	800	U	VS51B	90-96			MES 301-6	139 zł			
VZ	800	Marauder	WVBM	97-09			MES 301-6	139 zł			
RF	900	R	GT73B	94-96	P 189-10	160 zł	MES 342-10	219 zł			
DL	1000	V-Strom	JS1BS	02-09			MES 410-9	199 zł			
GSXR	1000		WVBL,WVBZ	01-04	P 190-9	135 zł	MES 310-9	209 zł			
GSXR	1000			05-06	P 181-9	144 zł					
SV	1000		WVBX	03-08			MES 410-9	199 zł			
TL	1000	S	AG111	97-98	P 177-9	144 zł	MES 414-9	199 zł			

PRZEKŁADKI STALOWE SPRZĘGŁA M O T O C Y K L E



PRZEKŁADKI STALOWE SPRZĘGŁA

Lucas



Model	Rok	EBS		Lucas		Newfren		
		Kod	Cena	Kod	Cena	Kod	Szt.	Cena

SUZUKI c.d.

GSX	1100	F	GV72C	88-94	P 189-10	160 zł	MES 342-10	219 zł			
GSX	1100	G	GV74A	91-94	P 189-10	160 zł	MES 342-10	219 zł			
GSXR	1100		GV74CD	86-88	P 189-10	160 zł	MES 342-10	219 zł			
GSXR	1100		GV73C	89-92	P 189-10	160 zł	MES 342-10	219 zł			
GSXR	1100	W	GU75C	93-94	P 189-10	160 zł	MES 342-10	219 zł			
GSXR	1100	W	GU75C	95-97	P 189-10	160 zł	MES 342-10	219 zł			
GSF	1200	Bandit	all	96-06	P 177-9	144 zł	MES 414-9	199 zł			
GSX	1200	FS	A3	99-00	P 177-9	144 zł	MES 414-9	199 zł			
GSF	1250	Bandit	WVCH	07-09			MES 328-8	179 zł			
	1300	B-King	WVCR	08-			MES 410-9	199 zł			
GSX	1300	R Hayabusa		99-10	P 097-7 P 102-2	144 zł	MES 410-9	199 zł			
VS	1400	Intruder	VX51L/LD	88-03			MES 344-9	199 zł			
VL	1500	Intruder	AL	98-09			MES 340-8	179 zł	F.1972C	8	128 zł

YAMAHA

DT	80	LC2	53V	87-96	P 046-4	60 zł	MES 317-4	94 zł			
DT	125	R,RE,X	4BL,3RM	92-07	P 046-6	90 zł	MES 317-6	134 zł			
SR	125		3MW8	96-03			MES 313-3	79 zł			
TDR	125		4GW1	90-03	P 046-6	90 zł	MES 317-6	134 zł			
TTR	125			00-09	P 002-4	56 zł					
TW	125	Trailway	DE01	99-01			MES 313-3	79 zł			
TZR	125			87-97	P 046-6	90 zł	MES 317-6	134 zł	F.1845C	6	90 zł
XT	125	R/X	74	05-10	P 046-4	60 zł	MES 317-4	94 zł			
YBR	125			05-10			MES 331-4	94 zł			
TW	200			87-09	P 057-4	60 zł					
TTR	250			00-04					F.2815C	6	84 zł
XV	250	Virago	3LS,3LW	89-99			MES 315-4	94 zł			
XVS	250		VG03	01-04			MES 315-4	94 zł			
XT	350		55V,59Y	85-00	PS 008B*	96 zł	MES 407-6	134 zł	F.1831C	6	84 zł
SR	500		48T,3EB	78-95			MES 318-7	159 zł	F.1838C	7	105 zł
XT	500		1U6	77-89			MES 318-7	159 zł	F.1838C	7	105 zł
XV	535	SE,N,H	3BR,2YL	87-02			MES 404-6	134 zł	F.1856C	6	90 zł
XJ	550		4V8	81-83			MES 325-7	164 zł			
XT	550		5Y3	83			MES 318-7	159 zł	F.1838C	7	105 zł
FZS	600	Fazer		98-03					F.1801C	8	120 zł
FZ6	600	Fazer, S Fazer	RJ07/RJ14	04-09			MES 315-7	159 zł	F.1836C	7	105 zł
FZR	600	H,M,N	3HE, 3RG	89-93			MES 320-8	179 zł			
TT	600		59X,2AG,2J	85-93	P 061-8	120 zł	MES 318-8	179 zł	F.1838C	8	120 zł
TT	600		4LW	94-03	P 061-8	120 zł	MES 318-8	179 zł	F.1838C	8	120 zł
TT	600	RE	DJ01	04-	P 061-7	105 zł	MES 318-7	159 zł	F.1838C	7	105 zł
XJ	600		51J, 3KM, 3KN	84-90			MES 401-8	179 zł	F.1836C	8	120 zł
XJ	600	Diversion	4BR, 4LX, RJ01	91-03			MES 401-8	179 zł	F.1836C	8	120 zł
XT	600	E	3TB,3UW	90-03	P 061-7	105 zł	MES 318-7	159 zł	F.1838C	7	105 zł
XT	600	H,N		86-89	P 061-7	105 zł	MES 318-7	159 zł	F.1838C	7	105 zł
XT	600	Z	1VJ	83-85	P 061-7	105 zł	MES 318-7	159 zł	F.1838C	7	105 zł
XT	600	Z	1VJ	86-87	P 061-7	105 zł	MES 318-7	159 zł	F.1838C	7	105 zł
XT	600	Z	3AJ	88-00	P 061-7	105 zł	MES 318-7	159 zł	F.1838C	7	105 zł
YZF	600	Thunder Cat		96-03	P 125-8	120 zł			F.2830C	8	120 zł
YZF	600	R6	RJ03	99-02			MES 315-7	159 zł	F.1836C	7	105 zł
YZF	600	R6	RJ05,RJ09	03-05			MES 315-7	159 zł	F.1836C	7	105 zł
YZF	600	R6		06-09			MES 315-8	184 zł			
XVS	650	Drag Star	4VR/XR, VM02/03/04	97-07			MES 404-7	159 zł	F.1856C	7	105 zł
XT	660	R,X	DM01	04-09			MES 352-6	134 zł	F.1894C	6	90 zł
XTZ	660	Tenere	4MY3	91-96	P 061-7	105 zł	MES 318-7	159 zł	F.1838C	7	105 zł
FZ	750			85-90			MES 403-8	179 zł	F.1836C	8	120 zł
FZX	750	Fazer	2JE	87-89			MES 403-8	179 zł	F.1836C	8	120 zł
XJ	750	all models		82-89			MES 315-7	159 zł	F.1836C	7	105 zł
XTZ	750	H,N	3LD/3WM	89-95			MES 403-8	179 zł	F.1836C	8	120 zł
XV	750	SE	5G5	81-83			MES 315-7	159 zł	F.1864C	7	105 zł
XV	750	Virago	4PW	92-97			MES 405-8	179 zł	F.1864C	8	120 zł

PRZEKŁADKI STALOWE SPRZĘGŁA M O T O C Y K L E



PRZEKŁADKI STALOWE SPRZĘGŁA

Model				Rok	EBS		Lucas		Newfren		
					Kod	Cena	Kod	Cena	Kod	Szt.	Cena
YAMAHA c.d.											
YZF	750	R, SP	4HN, 4HT	93-97			MES 315-8	184 zł	F.1836C	8	120 zł
TDM	850	H,N	3VD, 4CM	91-95			MES 403-8	179 zł	F.1836C	8	120 zł
TDM	850		4TX	96-01			MES 315-8	184 zł			
TDM	900		all	02-10			MES 315-8	184 zł	F.1836C	8	120 zł
XJ	900		all	83-94			MES 315-7	159 zł	F.1836C	7	105 zł
XJ	900	S, Diversion	4KM	94-03			MES 403-8	179 zł			
FZR	1000	Genesis	2LA	87-88			MES 315-8	184 zł			
FZR	1000	R, Exup	3LE	89-95			MES 315-8	184 zł			
FZS	1000	Fazer	RN06,RN14	01-05			MES 315-8	184 zł			
FZ1	1000	Fazer		06-08					F.2844C	8	128 zł
GTS	1000	A	4BH	93-97			MES 315-8	184 zł			
XV	1000	SE	23W	83-86			MES 405-8	179 zł	F.1864C	8	120 zł
YZF	1000	Thunder Ace	4VD	97-02			MES 315-8	184 zł			
YZF	1000	R1	RN01	98			MES 406-6	139 zł			
YZF	1000	R1	RN01,RN04	99-02			MES 319-7	159 zł			
YZF	1000	R1	RN09	03			MES 319-7	159 zł			
YZF	1000	R1		04-07					F.2844C	8	120 zł
BT	1100	Bulldog	RP05	02-06			MES 405-8	179 zł	F.1864C	8	120 zł
XV	1100	Virago	3LP	89-99			MES 405-8	179 zł	F.1864C	8	120 zł
XVS	1100	Drag Star	VP05	99-07			MES 405-8	179 zł	F.1864C	8	120 zł
FJ	1200		3YA	86-95			MES 319-7	159 zł			
VMX	1200	V-Max		89-04			MES 322-8	179 zł			
XJR	1200		4PU	95-98			MES 319-7	159 zł			
FJR	1300		RP04/RP08	01-10			MES 319-8	179 zł			
XJR	1300		all	99-10			MES 319-7	159 zł			
XVZ	1300	Royal Star	4YP	96-02			MES 322-8	179 zł			
XVS	1300	Midnight Star		07-10							
XV	1600	Wild Star	VP08	99-04			MES 322-8	179 zł			
MT-01	1700		RP12	05-10			MES 319-9	199 zł			

*PS 008B = P 008-5 + P 043-1

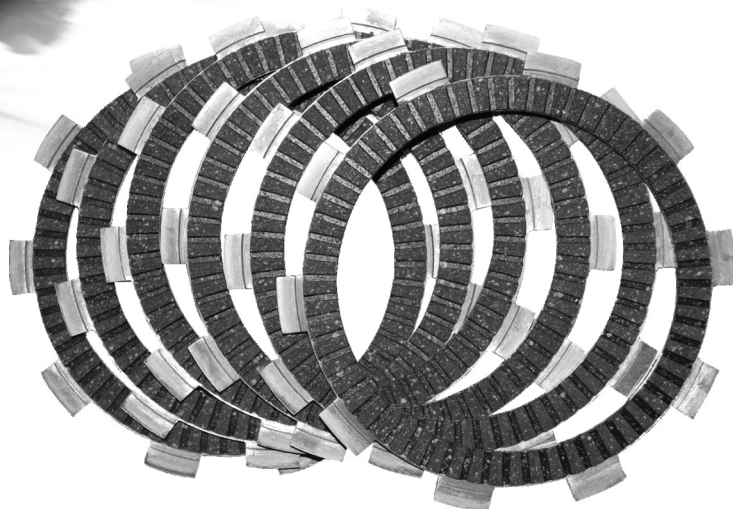

CENNIK ORAZ WYMIARY PRZEKŁADEK SPRZĘGŁA EBS - WG KODU



Kod	Wymiar zewn.	Wymiar wewn.	Grubość mm.	Ilość zębów	Cena za sztukę
P-001	152.3	108.2	1.4	29	16 zł
P-002	115.0	86.60	1.2	23	14 zł
P-003	115.0	86.60	1.6	23	13 zł
P-004	138.8	104.4	1.5	28	15 zł
P-005	124.9	90.3	1.5	24	14 zł
P-006	120.2	84.30	1.5	30	14 zł
P-007	139.9	105.2	1.2	37	15 zł
P-008	134.0	100.3	1.5	27	16 zł
P-009	115.0	87.1	1.2	30	14 zł
P-010	115.0	87.1	1.5	30	14 zł
P-011	125.0	90.1	1.5	24	14 zł
P-012	110.0	83.0	1.6	24	13 zł
P-013	119.9	90.2	1.5	20	14 zł
P-014	119.9	90.2	2.0	20	15 zł
P-015	137.8	108.0	2.0	36	15 zł
P-016	128.8	92.7	1.2	24	16 zł
P-017	123.1	84.1	1.5	22	14 zł
P-018	132.0	96.3	1.2	26	15 zł
P-019	122.0	91.0	1.5	30	15 zł
P-020	98.0	67.2	1.5	23	13 zł
P-021	120.2	88.8	1.2	30	14 zł
P-022	115.0	85.2	1.5	30	14 zł
P-023	138.8	104.4	1.2	28	13 zł
P-024	137.8	108.0	2.0	36	15 zł
P-025	115.0	87.0	1.4	30	14 zł
P-026	99.9	77.0	1.6	26	13 zł
P-027	109.8	82.3	1.4	24	13 zł
P-028	109.8	82.3	1.6	24	14 zł
P-029	98.9	70.2	1.6	30	13 zł
P-030	98.9	70.2	1.6	30	13 zł
P-031	120.2	84.3	1.6	30	14 zł
P-032	120.2	84.30	1.6	30	14 zł
P-033	120.2	84.3	1.5	30	14 zł
P-034	139.9	105.2	1.5	37	15 zł
P-035	139.9	105.2	1.5	37	15 zł
P-036	137.8	108.0	1.6	36	15 zł
P-037	114.8	86.6	1.2	23	14 zł
P-038	141.9	105.4	1.5	30	15 zł
P-039	115.0	87.1	2.0	30	13 zł
P-040	124.8	90.3	1.4	24	15 zł
P-041	124.8	90.3	1.4	24	15 zł
P-042	109.8	85.50	1.6	34	14 zł
P-043	134.0	100.3	2.0	27	16 zł
P-044	123.9	91.7	1.6	30	14 zł
P-045	134.0	100.3	1.2	27	15 zł
P-046	115.0	86.60	1.5	23	15 zł
P-047	145.7	112.5	1.5	30	15 zł
P-050	132.2	99.2	1.4	28	15 zł
P-051	120.2	84.3	1.5	30	14 zł
P-052	120.2	84.3	1.6	30	14 zł
P-053	124.7	90.0	2.0	24	15 zł
P-054	138.8	104.4	1.4	28	15 zł
P-055	145.7	112.5	2.0	30	15 zł
P-056	138.6	104.4	1.4	28	15 zł
P-057	121.9	90.3	1.5	20	15 zł
P-058	145.7	112.5	1.5	30	16 zł
P-059	132.8	96.2	2.0	34	15 zł
P-060	134.0	100.3	2.0	27	15 zł
P-061	134.0	100.3	1.2	27	15 zł
P-062	137.8	108.0	1.6	36	15 zł
P-063	153.4	124.7	1.2	50	16 zł
P-064	150.8	115.6	1.6	30	16 zł
P-065	153.3	101.6	1.2	42	20 zł
P-066	150.8	115.6	4.8	30	-
P-070	114.8	86.6	2.0	23	13 zł
P-071	139.9	105.2	1.6	37	15 zł
P-072	124.8	90.3	1.4	24	15 zł
P-074	132.8	96.2	1.6	34	14 zł
P-075	139.9	105.2	2.0	37	16 zł
P-076	138.8	104.4	1.5	28	15 zł
P-077	145.7	112.5	1.5	30	15 zł
P-078	147.8	108.3	1.6	36	16 zł
P-079	145.7	112.5	1.6	30	15 zł
P-080	122.0	84.2	1.2	22	-
P-081	109.8	85.5	1.4	34	13 zł
P-082	147.5	113.3	1.4	22	16 zł
P-083	70.2	46.3	1.5	6	13 zł
P-084	134.9	98.5	2.0	16	15 zł
P-085	141.0	110.1	1.2	22	15 zł

Kod	Wymiar zewn.	Wymiar wewn.	Grubość mm.	Ilość zębów	Cena za sztukę
P-086	139.8	112.3	1.5	30	16 zł
P-087	139.8	112.0	5.0	30	-
P-088	134.2	100.2	1.2	27	16 zł
P-089	141.9	105.4	1.2	30	15 zł
P-090	151.0	121.5	1.6	32	16 zł
P-091	94.9	70.7	1.0	24	14 zł
P-096	147.8	108.3	2.0	36	16 zł
P-097	150.8	115.8	2.0	30	16 zł
P-099	123.9	91.7	1.2	30	14 zł
P-100	123.9	91.7	1.2	30	14 zł
P-101	124.7	90.0	1.6	24	16 zł
P-102	150.8	115.8	2.3	30	16 zł
P-103	124.8	93.1	2.3	25	15 zł
P-104	115.8	89.3	1.0	30	15 zł
P-106	134.6	100.3	1.0	35	15 zł
P-107	150.8	105.8	2.0	35	16 zł
P-109	138.8	104.4	2.0	28	16 zł
P-110	124.8	90.3	2.0	24	15 zł
P-111	134.5	100.0	1.0	24	15 zł
P-112	134.5	100.0	1.4	24	15 zł
P-115	113.0	83.5	1.2	30	14 zł
P-116	108.6	75.0	1.2	21	14 zł
P-117	113.0	83.5	1.2	30	14 zł
P-118	105.3	84.1	1.5	22	13 zł
P-120	109.8	85.5	2.0	34	13 zł
P-121	134.0	100.3	2.3	27	15 zł
P-122	141.9	105.4	2.0	30	15 zł
P-123	152.0	122.3-112.3	2.0	30	17 zł
P-124	152.0	122.3-112.3	1.6	30	17 zł
P-125	119.9	90.2	1.6	20	15 zł
P-126	134.0	100.3	1.6	27	16 zł
P-127	138.9	99.2	3.0	41	16 zł
P-128	151.8	99.2	2.0	41	16 zł
P-129	151.8	99.2	3.0	41	16 zł
P-130	139.0	99.2	3.0	41	16 zł
P-131	141.1	99.2	1.5	41	16 zł
P-133	145.6	108.2	1.6	36	15 zł
P-134	95.7	38.3	1.6	30	14 zł
P-135	145.7	112.5	2.6	30	16 zł
P-138	132.8	96.2	2.3	34	16 zł
P-139	132.8	96.2	2.6	34	16 zł
P-140	138.9	104.5	2.0	28	16 zł
P-141	151.8	99.2	1.2	41	16 zł
P-142	147.5	113.3	1.2	22	16 zł
P-143	109.8	82.3	1.2	24	15 zł
P-144	115.0	86.6	2.0	23	15 zł
P-145	145.6	108.2	2.0	36	16 zł
P-146	134.0	100.3	1.4	27	15 zł
P-154	147.5	113.3	1.5	22	15 zł
P-157	124.8	93.1	1.6	25	15 zł
P-158	116.2	87.2	1.5	35	15 zł
P-161	119.9	90.2	2.0	20	15 zł
P-163	114.9	83.8	1.6	20	15 zł
P-164	146.1	108.3	1.6	36	16 zł
P-165	124.8	93.1	2.5	25	16 zł
P-166	108.6	75.0	1.6	21	16 zł
P-168	134.0	100.0	1.0	27	16 zł
P-170	138.9	103.1	1.4	36	15 zł
P-172	152.0	112.3	1.5	30	16 zł
P-173	138.6	104.4	2.0	28	15 zł
P-174	147.6	113.1	1.6	36	16 zł
P-175	125.0	113.1	1.6	36	15 zł
P-176	124.8	93.1	2.6	25	16 zł
P-177	124.8	93.1	2.0	25	16 zł
P-178	138.8	103.8	2.3	28	17 zł
P-179	132.8	96.2	2.9	34	16 zł
P-180	142.0	105.0	2.3	30	16 zł
P-181	132.8	103.9	2.6	28	16 zł
P-182	132.8	103.9	2.5	28	16 zł
P-183	132.8	103.9	1.6	28	16 zł
P-184	139.9	112.1	2.0	30	16 zł
P-185	151.0	112.4	3.0	30	16 zł
P-186	139.0	103.9	1.6	28	15 zł
P-187	144.8	108.0	1.6	36	15 zł
P-188	144.8	108.2	2.0	36	15 zł
P-189	129.8	99.2	2.0	28	16 zł
P-190	133.0	96.2	5.2	34	15 zł
P-191	138.7	103.8	2.0	28	16 zł

PRZEKŁADKI STALOWE SPRZĘGŁA

Lucas



CENNIK ORAZ WYMIARY PRZEKŁADEK SPRZĘGŁA EBS - WG WYMIARU ZEWN.



PRZEKŁADKI STALOWE SPRZĘGŁA



510

Wymiar zewn.	Wymiar wewn.	Grubość mm.	Ilość zębów	Kod	Cena za sztukę
70.2	46.3	1.5	6	P-083	13 zł
94.9	70.7	1.0	24	P-091	14 zł
95.7	38.3	1.6	30	P-134	14 zł
98.0	67.2	1.5	23	P-020	13 zł
98.9	70.2	1.6	30	P-029	13 zł
98.9	70.2	1.6	30	P-030	13 zł
99.9	77.0	1.6	26	P-026	13 zł
105.3	84.1	1.5	22	P-118	13 zł
108.6	75.0	1.2	21	P-116	14 zł
108.6	75.0	1.6	21	P-166	16 zł
109.8	82.3	1.4	24	P-027	13 zł
109.8	82.3	1.6	24	P-028	14 zł
109.8	85.50	1.6	34	P-042	14 zł
109.8	85.5	1.4	34	P-081	13 zł
109.8	85.5	2.0	34	P-120	13 zł
109.8	82.3	1.2	24	P-143	15 zł
110.0	83.0	1.6	24	P-012	13 zł
113.0	83.5	1.2	30	P-115	14 zł
113.0	83.5	1.2	30	P-117	14 zł
114.8	86.6	1.2	23	P-037	14 zł
114.8	86.6	2.0	23	P-070	13 zł
114.9	83.8	1.6	20	P-163	15 zł
115.0	86.60	1.2	23	P-002	14 zł
115.0	86.60	1.6	23	P-003	13 zł
115.0	87.1	1.2	30	P-009	14 zł
115.0	87.1	1.5	30	P-010	14 zł
115.0	85.2	1.5	30	P-022	14 zł
115.0	87.0	1.4	30	P-025	14 zł
115.0	87.1	2.0	30	P-039	13 zł
115.0	86.60	1.5	23	P-046	15 zł
115.0	86.6	2.0	23	P-144	15 zł
115.8	89.3	1.0	30	P-104	15 zł
116.2	87.2	1.5	35	P-158	15 zł
119.9	90.2	1.5	20	P-013	14 zł
119.9	90.2	2.0	20	P-014	15 zł
119.9	90.2	1.6	20	P-125	15 zł
119.9	90.2	2.0	20	P-161	15 zł
120.2	84.30	1.5	30	P-006	14 zł
120.2	88.8	1.2	30	P-021	14 zł
120.2	84.3	1.6	30	P-031	14 zł
120.2	84.30	1.6	30	P-032	14 zł
120.2	84.3	1.5	30	P-033	14 zł
120.2	84.3	1.5	30	P-051	14 zł
120.2	84.3	1.6	30	P-052	14 zł
121.9	90.3	1.5	20	P-057	15 zł
122.0	91.0	1.5	30	P-019	15 zł
122.0	84.2	1.2	22	P-080	-
123.1	84.1	1.5	22	P-017	14 zł
123.9	91.7	1.6	30	P-044	14 zł
123.9	91.7	1.2	30	P-099	14 zł
123.9	91.7	1.2	30	P-100	14 zł
124.7	90.0	2.0	24	P-053	15 zł
124.7	90.0	1.6	24	P-101	16 zł
124.8	90.3	1.4	24	P-040	15 zł
124.8	90.3	1.4	24	P-041	15 zł
124.8	90.3	1.4	24	P-072	15 zł
124.8	93.1	2.3	25	P-103	15 zł
124.8	90.3	2.0	24	P-110	15 zł
124.8	93.1	1.6	25	P-157	15 zł
124.8	93.1	2.5	25	P-165	16 zł
124.8	93.1	2.6	25	P-176	16 zł
124.8	93.1	2.0	25	P-177	16 zł
124.9	90.3	1.5	24	P-005	14 zł
125.0	90.1	1.5	24	P-011	14 zł
125.0	113.1	1.6	36	P-175	15 zł
128.8	92.7	1.2	24	P-016	16 zł
129.8	99.2	2.0	28	P-189	16 zł
132.8	96.2	2.3	34	P-138	16 zł
132.0	96.3	1.2	26	P-018	15 zł
132.2	99.2	1.4	28	P-050	15 zł
132.8	96.2	2.0	34	P-059	15 zł
132.8	96.2	1.6	34	P-074	14 zł
132.8	96.2	2.6	34	P-139	16 zł
132.8	96.2	2.9	34	P-179	16 zł
132.8	103.9	2.6	28	P-181	16 zł
132.8	103.9	2.5	28	P-182	16 zł
132.8	103.9	1.6	28	P-183	16 zł
133.0	96.2	5.2	34	P-190	15 zł
134.0	100.3	1.5	27	P-008	16 zł

Wymiar zewn.	Wymiar wewn.	Grubość mm.	Ilość zębów	Kod	Cena za sztukę
134.0	100.3	2.0	27	P-043	16 zł
134.0	100.3	1.2	27	P-045	15 zł
134.0	100.3	2.0	27	P-060	15 zł
134.0	100.3	1.2	27	P-061	15 zł
134.0	100.3	2.3	27	P-121	15 zł
134.0	100.3	1.6	27	P-126	16 zł
134.0	100.3	1.4	27	P-146	15 zł
134.0	100.0	1.0	27	P-168	16 zł
134.2	100.2	1.2	27	P-088	16 zł
134.5	100.0	1.0	24	P-111	15 zł
134.5	100.0	1.4	24	P-112	15 zł
134.6	100.3	1.0	35	P-106	15 zł
134.9	98.5	2.0	16	P-084	15 zł
137.8	108.0	2.0	36	P-015	15 zł
137.8	108.0	2.0	36	P-024	15 zł
137.8	108.0	1.6	36	P-036	15 zł
137.8	108.0	1.6	36	P-062	15 zł
138.6	104.4	1.4	28	P-056	15 zł
138.6	104.4	2.0	28	P-173	15 zł
138.7	103.8	2.0	28	P-191	16 zł
138.8	104.4	1.5	28	P-004	15 zł
138.8	104.4	1.2	28	P-023	13 zł
138.8	104.4	1.4	28	P-054	15 zł
138.8	104.4	1.5	28	P-076	15 zł
138.8	104.4	2.0	28	P-109	16 zł
138.8	103.8	2.3	28	P-178	17 zł
138.9	99.2	3.0	41	P-127	16 zł
138.9	104.5	2.0	28	P-140	16 zł
138.9	103.1	1.4	36	P-170	15 zł
139.0	99.2	3.0	41	P-130	16 zł
139.0	103.9	1.6	28	P-186	15 zł
139.8	112.3	1.5	30	P-086	16 zł
139.8	112.0	5.0	30	P-087	-
139.9	105.2	1.2	37	P-007	15 zł
139.9	105.2	1.5	37	P-034	15 zł
139.9	105.2	1.5	37	P-035	15 zł
139.9	105.2	1.6	37	P-071	15 zł
139.9	105.2	2.0	37	P-075	16 zł
139.9	112.1	2.0	30	P-184	16 zł
141.0	110.1	1.2	22	P-085	15 zł
141.1	99.2	1.5	41	P-131	16 zł
141.9	105.4	1.5	30	P-038	15 zł
141.9	105.4	1.2	30	P-089	15 zł
141.9	105.4	2.0	30	P-122	15 zł
142.0	105.0	2.3	30	P-180	16 zł
144.8	108.0	1.6	36	P-187	15 zł
144.8	108.2	2.0	36	P-188	15 zł
145.6	108.2	1.6	36	P-133	15 zł
145.6	108.2	2.0	36	P-145	16 zł
145.7	112.5	1.5	30	P-047	15 zł
145.7	112.5	2.0	30	P-055	15 zł
145.7	112.5	1.5	30	P-058	16 zł
145.7	112.5	1.5	30	P-077	15 zł
145.7	112.5	1.6	30	P-079	15 zł
145.7	112.5	2.6	30	P-135	16 zł
146.1	108.3	1.6	36	P-164	16 zł
147.5	113.3	1.4	22	P-082	16 zł
147.5	113.3	1.2	22	P-142	16 zł
147.5	113.3	1.5	22	P-154	15 zł
147.6	113.1	1.6	36	P-174	16 zł
147.8	108.3	1.6	36	P-078	16 zł
147.8	108.3	2.0	36	P-096	16 zł
150.8	115.6	1.6	30	P-064	16 zł
150.8	115.6	4.8	30	P-066	-
150.8	115.8	2.0	30	P-097	16 zł
150.8	115.8	2.3	30	P-102	16 zł
150.8	105.8	2.0	35	P-107	16 zł
151.0	121.5	1.6	32	P-090	16 zł
151.0	112.4	3.0	30	P-185	16 zł
151.8	99.2	2.0	41	P-128	16 zł
151.8	99.2	3.0	41	P-129	16 zł
151.8	99.2	1.2	41	P-141	16 zł
152.0	122.3-112.3	2.0	30	P-123	17 zł
152.0	122.3-112.3	1.6	30	P-124	17 zł
152.0	112.3	1.5	30	P-172	16 zł
152.3	108.2	1.4	29	P-001	16 zł
153.3	101.6	1.2	42	P-065	20 zł
153.4	124.7	1.2	50	P-063	16 zł

WYMIARY PRZEKŁADEK SPRZĘGŁOWYCH LUCAS



WYMIARY PRZEKŁADEK SPRZĘGŁOWYCH LUCAS

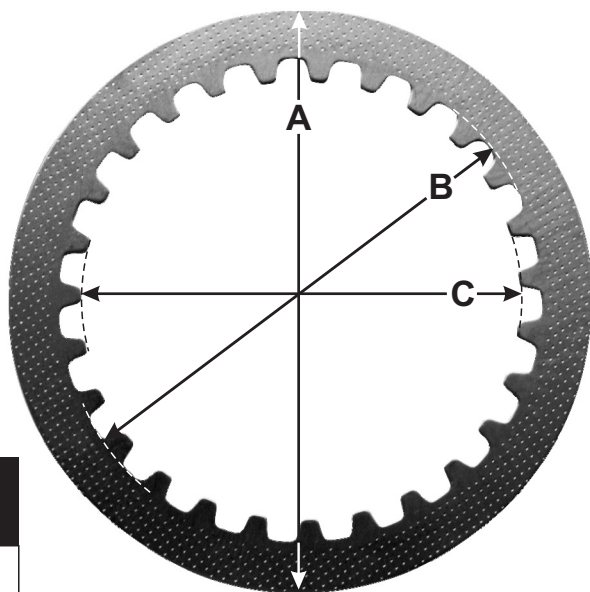

Numer	Ilość	Wymiar A	Wymiar B	Wymiar C	Wymiar D
MES 301-4	4	139	113	102,5	1,5
MES 301-6	6	139	113	102,5	1,5
MES 302-6	6	132	103,5	96	1,6
MES 303-5	5	145	122	112	2
MES 303-6	6	145	122	112	2
MES 303-7	7	145	122	112	2
MES 304-7	7	145	122	112	1,5
MES 305-6	6	145	122	112	2,3
MES 305-8	8	145	122	112	2,3
MES 306-7	7	140	114	105	1,5
MES 308-7	7	145	122	112	1,6
MES 309-4	4	110	90	85,2	1,4
MES 309-5	5	110	90	85,2	1,4
MES 309-7	7	110	90	85,2	1,4
MES 310-5	5	125	97	90	1,4
MES 310-9	9	133	103,5	96	2,3
MES 311-8	8	151	122	112	2,8
MES 312-11	11	139	110	103,8	1,6
MES 313-3	3	122	101	89,3	1,6
MES 314-7	7	134	110	100	1,6
MES 315-4	4	134	110	100	2
MES 315-7	7	134	110	100	2
MES 315-8	8	134	110	100	2
MES 317-4	4	115	94,5	86,5	1,2
MES 317-6	6	115	94,5	86,5	1,2
MES 318-7	7	134	110	100	1,2
MES 318-8	8	134	110	100	1,2
MES 319-7	7	151	122	112	2
MES 319-8	8	151	122	112	2
MES 320-8	8	115	94,5	86,5	2
MES 321-7	7	124	99	91,7	1,6
MES 322-8	8	158	130	120	2,25
MES 323-7	7	124	99	91,7	1,2
MES 324-8	8	122	101	89,3	1,5
MES 325-6	6	134	110	100	1,5
MES 325-7	7	134	110	100	1,5
MES 326-4	4	125	97	90	1,5
MES 326-5	5	125	97	90	1,5
MES 326-6	6	125	97	90	1,5
MES 326-7	7	125	97	90	1,5
MES 327-8	8	125	99	93	2,3
MES 328-6	6	142	114,5	105	1

Numer	Ilość	Wymiar A	Wymiar B	Wymiar C	Wymiar D
MES 328-7	7	142	114,5	105	1
MES 329-5	5	138	119	112	2
MES 329-6	6	138	119	112	2
MES 330-7	7	125	99	93	2,5
MES 331-4	4	108	90,4	82,8	1,6
MES 332-6	6	139	113,2	105	1,5
MES 332-8	8	139	113,2	105	1,5
MES 333-5	5	138,4	111	104,7	2
MES 333-8	8	138,4	111	104,7	2
MES 333-9	9	138,4	111	104,7	2
MES 334-6	6	125	97	90	2
MES 335-9	9	139	110	103,8	2
MES 336-4	4	125	97	90	1,6
MES 336-7	7	125	97	90	1,6
MES 337-6	6	138	115,3	108,2	1,5
MES 337-8	8	138	115,3	108,2	1,5
MES 338-8	8	138	115,3	108,2	2
MES 339-9	9	148	115,3	108,2	2
MES 340-8	8	148	115,3	108,2	1,5
MES 341-9	9	145	115,3	108,2	1,5
MES 342-10	10	130	107	99	2
MES 343-6	6	125	99	93	2
MES 343-8	8	125	99	93	2
MES 344-7	7	139	115,2	104,2	2
MES 344-9	9	139	115,2	104,2	2
MES 345-4	4	115	96	87	2
MES 346-7	7	132	107	99	1,4
MES 347-4	4	115	95,8	86,8	1,6
MES 348-8	8	145	115,3	108,2	2
MES 349-7	7	120	93	85	1,5
MES 350-8	8	142	119	110	1,2
MES 351-7	7	148	123	113	1,5
MES 352-6	6	142	114,5	105	1,6
MES 353-8	8	145	115,3	108,2	2
MES 354-7	7	132	103,5	96	1,6
MES 355-7	7	151	126	115,5	1,6
MES 401-8	7	134	110	100	1,6
MES 401-8	1	134	110	100	2,3
MES 402-6	4	134	110	100	2
MES 402-6	2	134	110	100	1,5
MES 403-8	7	134	110	100	2
MES 403-8	1	134	110	100	2,3
MES 404-6	5	142	114,5	105	1,6
MES 404-6	1	142	114,5	105	2,5
MES 404-7	6	142	114,5	105	1,6
MES 404-7	1	142	114,5	105	2,5
MES 405-8	7	142	114,5	105	1,6
MES 405-8	1	142	114,5	105	2,5
MES 406-6	6	151	122	112	2
MES 407-6	5	134	110	100	1,5
MES 407-6	1	134	110	100	2
MES 408-8	7	125	99	93	2,5
MES 408-8	1	125	99	93	2,3
MES 409-8	7	125	99	93	2,3
MES 409-8	1	125	99	93	2,5
MES 410-9	7	151	126	115,5	2,25
MES 410-9	2	151	126	115,5	2,25
MES 411-7	5	139	113,2	105	1,5
MES 411-7	2	139	113,2	105	1,6
MES 412-8	7	148	115,3	108,2	1,5
MES 412-8	1	148	115,3	108,2	2
MES 413-9	7	125	99	93	2
MES 413-9	2	125	99	93	1,5
MES 414-9	7	125	99	93	1,5
MES 414-9	2	125	99	93	2