

CENNIK ORAZ WYMIARY PRZEKŁADEK SPRZĘGŁA EBS - WG KODU



Kod	Wymiar zewn.	Wymiar wewn.	Grubość mm.	Ilość zębów	Cena za sztukę
P-001	152.3	108.2	1.4	29	16 zł
P-002	115.0	86.60	1.2	23	14 zł
P-003	115.0	86.60	1.6	23	13 zł
P-004	138.8	104.4	1.5	28	15 zł
P-005	124.9	90.3	1.5	24	14 zł
P-006	120.2	84.30	1.5	30	14 zł
P-007	139.9	105.2	1.2	37	15 zł
P-008	134.0	100.3	1.5	27	16 zł
P-009	115.0	87.1	1.2	30	14 zł
P-010	115.0	87.1	1.5	30	14 zł
P-011	125.0	90.1	1.5	24	14 zł
P-012	110.0	83.0	1.6	24	13 zł
P-013	119.9	90.2	1.5	20	14 zł
P-014	119.9	90.2	2.0	20	15 zł
P-015	137.8	108.0	2.0	36	15 zł
P-016	128.8	92.7	1.2	24	16 zł
P-017	123.1	84.1	1.5	22	14 zł
P-018	132.0	96.3	1.2	26	15 zł
P-019	122.0	91.0	1.5	30	15 zł
P-020	98.0	67.2	1.5	23	13 zł
P-021	120.2	88.8	1.2	30	14 zł
P-022	115.0	85.2	1.5	30	14 zł
P-023	138.8	104.4	1.2	28	13 zł
P-024	137.8	108.0	2.0	36	15 zł
P-025	115.0	87.0	1.4	30	14 zł
P-026	99.9	77.0	1.6	26	13 zł
P-027	109.8	82.3	1.4	24	13 zł
P-028	109.8	82.3	1.6	24	14 zł
P-029	98.9	70.2	1.6	30	13 zł
P-030	98.9	70.2	1.6	30	13 zł
P-031	120.2	84.3	1.6	30	14 zł
P-032	120.2	84.30	1.6	30	14 zł
P-033	120.2	84.3	1.5	30	14 zł
P-034	139.9	105.2	1.5	37	15 zł
P-035	139.9	105.2	1.5	37	15 zł
P-036	137.8	108.0	1.6	36	15 zł
P-037	114.8	86.6	1.2	23	14 zł
P-038	141.9	105.4	1.5	30	15 zł
P-039	115.0	87.1	2.0	30	13 zł
P-040	124.8	90.3	1.4	24	15 zł
P-041	124.8	90.3	1.4	24	15 zł
P-042	109.8	85.50	1.6	34	14 zł
P-043	134.0	100.3	2.0	27	16 zł
P-044	123.9	91.7	1.6	30	14 zł
P-045	134.0	100.3	1.2	27	15 zł
P-046	115.0	86.60	1.5	23	15 zł
P-047	145.7	112.5	1.5	30	15 zł
P-050	132.2	99.2	1.4	28	15 zł
P-051	120.2	84.3	1.5	30	14 zł
P-052	120.2	84.3	1.6	30	14 zł
P-053	124.7	90.0	2.0	24	15 zł
P-054	138.8	104.4	1.4	28	15 zł
P-055	145.7	112.5	2.0	30	15 zł
P-056	138.6	104.4	1.4	28	15 zł
P-057	121.9	90.3	1.5	20	15 zł
P-058	145.7	112.5	1.5	30	16 zł
P-059	132.8	96.2	2.0	34	15 zł
P-060	134.0	100.3	2.0	27	15 zł
P-061	134.0	100.3	1.2	27	15 zł
P-062	137.8	108.0	1.6	36	15 zł
P-063	153.4	124.7	1.2	50	16 zł
P-064	150.8	115.6	1.6	30	16 zł
P-065	153.3	101.6	1.2	42	20 zł
P-066	150.8	115.6	4.8	30	-
P-070	114.8	86.6	2.0	23	13 zł
P-071	139.9	105.2	1.6	37	15 zł
P-072	124.8	90.3	1.4	24	15 zł
P-074	132.8	96.2	1.6	34	14 zł
P-075	139.9	105.2	2.0	37	16 zł
P-076	138.8	104.4	1.5	28	15 zł
P-077	145.7	112.5	1.5	30	15 zł
P-078	147.8	108.3	1.6	36	16 zł
P-079	145.7	112.5	1.6	30	15 zł
P-080	122.0	84.2	1.2	22	-
P-081	109.8	85.5	1.4	34	13 zł
P-082	147.5	113.3	1.4	22	16 zł
P-083	70.2	46.3	1.5	6	13 zł
P-084	134.9	98.5	2.0	16	15 zł
P-085	141.0	110.1	1.2	22	15 zł

Kod	Wymiar zewn.	Wymiar wewn.	Grubość mm.	Ilość zębów	Cena za sztukę
P-086	139.8	112.3	1.5	30	16 zł
P-087	139.8	112.0	5.0	30	-
P-088	134.2	100.2	1.2	27	16 zł
P-089	141.9	105.4	1.2	30	15 zł
P-090	151.0	121.5	1.6	32	16 zł
P-091	94.9	70.7	1.0	24	14 zł
P-096	147.8	108.3	2.0	36	16 zł
P-097	150.8	115.8	2.0	30	16 zł
P-099	123.9	91.7	1.2	30	14 zł
P-100	123.9	91.7	1.2	30	14 zł
P-101	124.7	90.0	1.6	24	16 zł
P-102	150.8	115.8	2.3	30	16 zł
P-103	124.8	93.1	2.3	25	15 zł
P-104	115.8	89.3	1.0	30	15 zł
P-106	134.6	100.3	1.0	35	15 zł
P-107	150.8	105.8	2.0	35	16 zł
P-109	138.8	104.4	2.0	28	16 zł
P-110	124.8	90.3	2.0	24	15 zł
P-111	134.5	100.0	1.0	24	15 zł
P-112	134.5	100.0	1.4	24	15 zł
P-115	113.0	83.5	1.2	30	14 zł
P-116	108.6	75.0	1.2	21	14 zł
P-117	113.0	83.5	1.2	30	14 zł
P-118	105.3	84.1	1.5	22	13 zł
P-120	109.8	85.5	2.0	34	13 zł
P-121	134.0	100.3	2.3	27	15 zł
P-122	141.9	105.4	2.0	30	15 zł
P-123	152.0	122.3-112.3	2.0	30	17 zł
P-124	152.0	122.3-112.3	1.6	30	17 zł
P-125	119.9	90.2	1.6	20	15 zł
P-126	134.0	100.3	1.6	27	16 zł
P-127	138.9	99.2	3.0	41	16 zł
P-128	151.8	99.2	2.0	41	16 zł
P-129	151.8	99.2	3.0	41	16 zł
P-130	139.0	99.2	3.0	41	16 zł
P-131	141.1	99.2	1.5	41	16 zł
P-133	145.6	108.2	1.6	36	15 zł
P-134	95.7	38.3	1.6	30	14 zł
P-135	145.7	112.5	2.6	30	16 zł
P-138	132.8	96.2	2.3	34	16 zł
P-139	132.8	96.2	2.6	34	16 zł
P-140	138.9	104.5	2.0	28	16 zł
P-141	151.8	99.2	1.2	41	16 zł
P-142	147.5	113.3	1.2	22	16 zł
P-143	109.8	82.3	1.2	24	15 zł
P-144	115.0	86.6	2.0	23	15 zł
P-145	145.6	108.2	2.0	36	16 zł
P-146	134.0	100.3	1.4	27	15 zł
P-154	147.5	113.3	1.5	22	15 zł
P-157	124.8	93.1	1.6	25	15 zł
P-158	116.2	87.2	1.5	35	15 zł
P-161	119.9	90.2	2.0	20	15 zł
P-163	114.9	83.8	1.6	20	15 zł
P-164	146.1	108.3	1.6	36	16 zł
P-165	124.8	93.1	2.5	25	16 zł
P-166	108.6	75.0	1.6	21	16 zł
P-168	134.0	100.0	1.0	27	16 zł
P-170	138.9	103.1	1.4	36	15 zł
P-172	152.0	112.3	1.5	30	16 zł
P-173	138.6	104.4	2.0	28	15 zł
P-174	147.6	113.1	1.6	36	16 zł
P-175	125.0	113.1	1.6	36	15 zł
P-176	124.8	93.1	2.6	25	16 zł
P-177	124.8	93.1	2.0	25	16 zł
P-178	138.8	103.8	2.3	28	17 zł
P-179	132.8	96.2	2.9	34	16 zł
P-180	142.0	105.0	2.3	30	16 zł
P-181	132.8	103.9	2.6	28	16 zł
P-182	132.8	103.9	2.5	28	16 zł
P-183	132.8	103.9	1.6	28	16 zł
P-184	139.9	112.1	2.0	30	16 zł
P-185	151.0	112.4	3.0	30	16 zł
P-186	139.0	103.9	1.6	28	15 zł
P-187	144.8	108.0	1.6	36	15 zł
P-188	144.8	108.2	2.0	36	15 zł
P-189	129.8	99.2	2.0	28	16 zł
P-190	133.0	96.2	5.2	34	15 zł
P-191	138.7	103.8	2.0	28	16 zł

PRZEKŁADKI STALOWE SPRZĘGŁA

Lucas



CENNIK ORAZ WYMIARY PRZEKŁADEK SPRZĘGŁA EBS - WG WYMIARU ZEWN.



PRZEKŁADKI STALOWE SPRZĘGŁA



510

Wymiar zewn.	Wymiar wewn.	Grubość mm.	Ilość zębów	Kod	Cena za sztukę
70.2	46.3	1.5	6	P-083	13 zł
94.9	70.7	1.0	24	P-091	14 zł
95.7	38.3	1.6	30	P-134	14 zł
98.0	67.2	1.5	23	P-020	13 zł
98.9	70.2	1.6	30	P-029	13 zł
98.9	70.2	1.6	30	P-030	13 zł
99.9	77.0	1.6	26	P-026	13 zł
105.3	84.1	1.5	22	P-118	13 zł
108.6	75.0	1.2	21	P-116	14 zł
108.6	75.0	1.6	21	P-166	16 zł
109.8	82.3	1.4	24	P-027	13 zł
109.8	82.3	1.6	24	P-028	14 zł
109.8	85.50	1.6	34	P-042	14 zł
109.8	85.5	1.4	34	P-081	13 zł
109.8	85.5	2.0	34	P-120	13 zł
109.8	82.3	1.2	24	P-143	15 zł
110.0	83.0	1.6	24	P-012	13 zł
113.0	83.5	1.2	30	P-115	14 zł
113.0	83.5	1.2	30	P-117	14 zł
114.8	86.6	1.2	23	P-037	14 zł
114.8	86.6	2.0	23	P-070	13 zł
114.9	83.8	1.6	20	P-163	15 zł
115.0	86.60	1.2	23	P-002	14 zł
115.0	86.60	1.6	23	P-003	13 zł
115.0	87.1	1.2	30	P-009	14 zł
115.0	87.1	1.5	30	P-010	14 zł
115.0	85.2	1.5	30	P-022	14 zł
115.0	87.0	1.4	30	P-025	14 zł
115.0	87.1	2.0	30	P-039	13 zł
115.0	86.60	1.5	23	P-046	15 zł
115.0	86.6	2.0	23	P-144	15 zł
115.8	89.3	1.0	30	P-104	15 zł
116.2	87.2	1.5	35	P-158	15 zł
119.9	90.2	1.5	20	P-013	14 zł
119.9	90.2	2.0	20	P-014	15 zł
119.9	90.2	1.6	20	P-125	15 zł
119.9	90.2	2.0	20	P-161	15 zł
120.2	84.30	1.5	30	P-006	14 zł
120.2	88.8	1.2	30	P-021	14 zł
120.2	84.3	1.6	30	P-031	14 zł
120.2	84.30	1.6	30	P-032	14 zł
120.2	84.3	1.5	30	P-033	14 zł
120.2	84.3	1.5	30	P-051	14 zł
120.2	84.3	1.6	30	P-052	14 zł
121.9	90.3	1.5	20	P-057	15 zł
122.0	91.0	1.5	30	P-019	15 zł
122.0	84.2	1.2	22	P-080	-
123.1	84.1	1.5	22	P-017	14 zł
123.9	91.7	1.6	30	P-044	14 zł
123.9	91.7	1.2	30	P-099	14 zł
123.9	91.7	1.2	30	P-100	14 zł
124.7	90.0	2.0	24	P-053	15 zł
124.7	90.0	1.6	24	P-101	16 zł
124.8	90.3	1.4	24	P-040	15 zł
124.8	90.3	1.4	24	P-041	15 zł
124.8	90.3	1.4	24	P-072	15 zł
124.8	93.1	2.3	25	P-103	15 zł
124.8	90.3	2.0	24	P-110	15 zł
124.8	93.1	1.6	25	P-157	15 zł
124.8	93.1	2.5	25	P-165	16 zł
124.8	93.1	2.6	25	P-176	16 zł
124.8	93.1	2.0	25	P-177	16 zł
124.9	90.3	1.5	24	P-005	14 zł
125.0	90.1	1.5	24	P-011	14 zł
125.0	113.1	1.6	36	P-175	15 zł
128.8	92.7	1.2	24	P-016	16 zł
129.8	99.2	2.0	28	P-189	16 zł
132.8	96.2	2.3	34	P-138	16 zł
132.0	96.3	1.2	26	P-018	15 zł
132.2	99.2	1.4	28	P-050	15 zł
132.8	96.2	2.0	34	P-059	15 zł
132.8	96.2	1.6	34	P-074	14 zł
132.8	96.2	2.6	34	P-139	16 zł
132.8	96.2	2.9	34	P-179	16 zł
132.8	103.9	2.6	28	P-181	16 zł
132.8	103.9	2.5	28	P-182	16 zł
132.8	103.9	1.6	28	P-183	16 zł
133.0	96.2	5.2	34	P-190	15 zł
134.0	100.3	1.5	27	P-008	16 zł

Wymiar zewn.	Wymiar wewn.	Grubość mm.	Ilość zębów	Kod	Cena za sztukę
134.0	100.3	2.0	27	P-043	16 zł
134.0	100.3	1.2	27	P-045	15 zł
134.0	100.3	2.0	27	P-060	15 zł
134.0	100.3	1.2	27	P-061	15 zł
134.0	100.3	2.3	27	P-121	15 zł
134.0	100.3	1.6	27	P-126	16 zł
134.0	100.3	1.4	27	P-146	15 zł
134.0	100.0	1.0	27	P-168	16 zł
134.2	100.2	1.2	27	P-088	16 zł
134.5	100.0	1.0	24	P-111	15 zł
134.5	100.0	1.4	24	P-112	15 zł
134.6	100.3	1.0	35	P-106	15 zł
134.9	98.5	2.0	16	P-084	15 zł
137.8	108.0	2.0	36	P-015	15 zł
137.8	108.0	2.0	36	P-024	15 zł
137.8	108.0	1.6	36	P-036	15 zł
137.8	108.0	1.6	36	P-062	15 zł
138.6	104.4	1.4	28	P-056	15 zł
138.6	104.4	2.0	28	P-173	15 zł
138.7	103.8	2.0	28	P-191	16 zł
138.8	104.4	1.5	28	P-004	15 zł
138.8	104.4	1.2	28	P-023	13 zł
138.8	104.4	1.4	28	P-054	15 zł
138.8	104.4	1.5	28	P-076	15 zł
138.8	104.4	2.0	28	P-109	16 zł
138.8	103.8	2.3	28	P-178	17 zł
138.9	99.2	3.0	41	P-127	16 zł
138.9	104.5	2.0	28	P-140	16 zł
138.9	103.1	1.4	36	P-170	15 zł
139.0	99.2	3.0	41	P-130	16 zł
139.0	103.9	1.6	28	P-186	15 zł
139.8	112.3	1.5	30	P-086	16 zł
139.8	112.0	5.0	30	P-087	-
139.9	105.2	1.2	37	P-007	15 zł
139.9	105.2	1.5	37	P-034	15 zł
139.9	105.2	1.5	37	P-035	15 zł
139.9	105.2	1.6	37	P-071	15 zł
139.9	105.2	2.0	37	P-075	16 zł
139.9	112.1	2.0	30	P-184	16 zł
141.0	110.1	1.2	22	P-085	15 zł
141.1	99.2	1.5	41	P-131	16 zł
141.9	105.4	1.5	30	P-038	15 zł
141.9	105.4	1.2	30	P-089	15 zł
141.9	105.4	2.0	30	P-122	15 zł
142.0	105.0	2.3	30	P-180	16 zł
144.8	108.0	1.6	36	P-187	15 zł
144.8	108.2	2.0	36	P-188	15 zł
145.6	108.2	1.6	36	P-133	15 zł
145.6	108.2	2.0	36	P-145	16 zł
145.7	112.5	1.5	30	P-047	15 zł
145.7	112.5	2.0	30	P-055	15 zł
145.7	112.5	1.5	30	P-058	16 zł
145.7	112.5	1.5	30	P-077	15 zł
145.7	112.5	1.6	30	P-079	15 zł
145.7	112.5	2.6	30	P-135	16 zł
146.1	108.3	1.6	36	P-164	16 zł
147.5	113.3	1.4	22	P-082	16 zł
147.5	113.3	1.2	22	P-142	16 zł
147.5	113.3	1.5	22	P-154	15 zł
147.6	113.1	1.6	36	P-174	16 zł
147.8	108.3	1.6	36	P-078	16 zł
147.8	108.3	2.0	36	P-096	16 zł
150.8	115.6	1.6	30	P-064	16 zł
150.8	115.6	4.8	30	P-066	-
150.8	115.8	2.0	30	P-097	16 zł
150.8	115.8	2.3	30	P-102	16 zł
150.8	105.8	2.0	35	P-107	16 zł
151.0	121.5	1.6	32	P-090	16 zł
151.0	112.4	3.0	30	P-185	16 zł
151.8	99.2	2.0	41	P-128	16 zł
151.8	99.2	3.0	41	P-129	16 zł
151.8	99.2	1.2	41	P-141	16 zł
152.0	122.3-112.3	2.0	30	P-123	17 zł
152.0	122.3-112.3	1.6	30	P-124	17 zł
152.0	112.3	1.5	30	P-172	16 zł
152.3	108.2	1.4	29	P-001	16 zł
153.3	101.6	1.2	42	P-065	20 zł
153.4	124.7	1.2	50	P-063	16 zł

WYMIARY PRZEKŁADEK SPRZĘGŁOWYCH LUCAS



WYMIARY PRZEKŁADEK SPRZĘGŁOWYCH LUCAS

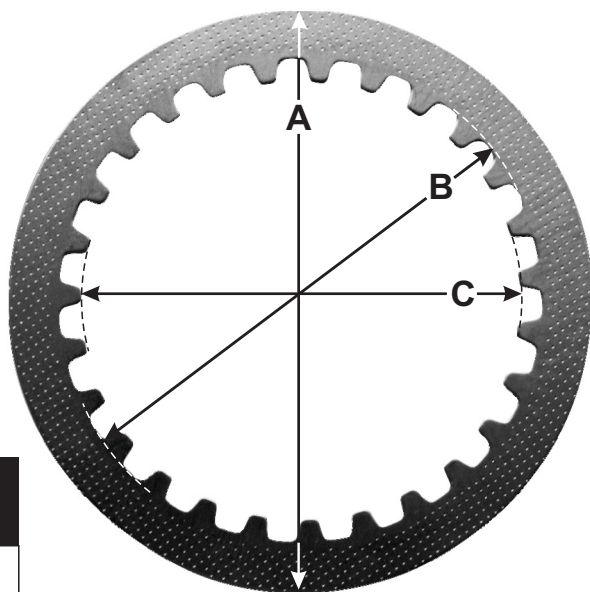

Numer	Ilość	Wymiar A	Wymiar B	Wymiar C	Wymiar D
MES 301-4	4	139	113	102,5	1,5
MES 301-6	6	139	113	102,5	1,5
MES 302-6	6	132	103,5	96	1,6
MES 303-5	5	145	122	112	2
MES 303-6	6	145	122	112	2
MES 303-7	7	145	122	112	2
MES 304-7	7	145	122	112	1,5
MES 305-6	6	145	122	112	2,3
MES 305-8	8	145	122	112	2,3
MES 306-7	7	140	114	105	1,5
MES 308-7	7	145	122	112	1,6
MES 309-4	4	110	90	85,2	1,4
MES 309-5	5	110	90	85,2	1,4
MES 309-7	7	110	90	85,2	1,4
MES 310-5	5	125	97	90	1,4
MES 310-9	9	133	103,5	96	2,3
MES 311-8	8	151	122	112	2,8
MES 312-11	11	139	110	103,8	1,6
MES 313-3	3	122	101	89,3	1,6
MES 314-7	7	134	110	100	1,6
MES 315-4	4	134	110	100	2
MES 315-7	7	134	110	100	2
MES 315-8	8	134	110	100	2
MES 317-4	4	115	94,5	86,5	1,2
MES 317-6	6	115	94,5	86,5	1,2
MES 318-7	7	134	110	100	1,2
MES 318-8	8	134	110	100	1,2
MES 319-7	7	151	122	112	2
MES 319-8	8	151	122	112	2
MES 320-8	8	115	94,5	86,5	2
MES 321-7	7	124	99	91,7	1,6
MES 322-8	8	158	130	120	2,25
MES 323-7	7	124	99	91,7	1,2
MES 324-8	8	122	101	89,3	1,5
MES 325-6	6	134	110	100	1,5
MES 325-7	7	134	110	100	1,5
MES 326-4	4	125	97	90	1,5
MES 326-5	5	125	97	90	1,5
MES 326-6	6	125	97	90	1,5
MES 326-7	7	125	97	90	1,5
MES 327-8	8	125	99	93	2,3
MES 328-6	6	142	114,5	105	1

Numer	Ilość	Wymiar A	Wymiar B	Wymiar C	Wymiar D
MES 328-7	7	142	114,5	105	1
MES 329-5	5	138	119	112	2
MES 329-6	6	138	119	112	2
MES 330-7	7	125	99	93	2,5
MES 331-4	4	108	90,4	82,8	1,6
MES 332-6	6	139	113,2	105	1,5
MES 332-8	8	139	113,2	105	1,5
MES 333-5	5	138,4	111	104,7	2
MES 333-8	8	138,4	111	104,7	2
MES 333-9	9	138,4	111	104,7	2
MES 334-6	6	125	97	90	2
MES 335-9	9	139	110	103,8	2
MES 336-4	4	125	97	90	1,6
MES 336-7	7	125	97	90	1,6
MES 337-6	6	138	115,3	108,2	1,5
MES 337-8	8	138	115,3	108,2	1,5
MES 338-8	8	138	115,3	108,2	2
MES 339-9	9	148	115,3	108,2	2
MES 340-8	8	148	115,3	108,2	1,5
MES 341-9	9	145	115,3	108,2	1,5
MES 342-10	10	130	107	99	2
MES 343-6	6	125	99	93	2
MES 343-8	8	125	99	93	2
MES 344-7	7	139	115,2	104,2	2
MES 344-9	9	139	115,2	104,2	2
MES 345-4	4	115	96	87	2
MES 346-7	7	132	107	99	1,4
MES 347-4	4	115	95,8	86,8	1,6
MES 348-8	8	145	115,3	108,2	2
MES 349-7	7	120	93	85	1,5
MES 350-8	8	142	119	110	1,2
MES 351-7	7	148	123	113	1,5
MES 352-6	6	142	114,5	105	1,6
MES 353-8	8	145	115,3	108,2	2
MES 354-7	7	132	103,5	96	1,6
MES 355-7	7	151	126	115,5	1,6
MES 401-8	7	134	110	100	1,6
MES 401-8	1	134	110	100	2,3
MES 402-6	4	134	110	100	2
MES 402-6	2	134	110	100	1,5
MES 403-8	7	134	110	100	2
MES 403-8	1	134	110	100	2,3
MES 404-6	5	142	114,5	105	1,6
MES 404-6	1	142	114,5	105	2,5
MES 404-7	6	142	114,5	105	1,6
MES 404-7	1	142	114,5	105	2,5
MES 405-8	7	142	114,5	105	1,6
MES 405-8	1	142	114,5	105	2,5
MES 406-6	6	151	122	112	2
MES 407-6	5	134	110	100	1,5
MES 407-6	1	134	110	100	2
MES 408-8	7	125	99	93	2,5
MES 408-8	1	125	99	93	2,3
MES 409-8	7	125	99	93	2,3
MES 409-8	1	125	99	93	2,5
MES 410-9	7	151	126	115,5	2,25
MES 410-9	2	151	126	115,5	2,25
MES 411-7	5	139	113,2	105	1,5
MES 411-7	2	139	113,2	105	1,6
MES 412-8	7	148	115,3	108,2	1,5
MES 412-8	1	148	115,3	108,2	2
MES 413-9	7	125	99	93	2
MES 413-9	2	125	99	93	1,5
MES 414-9	7	125	99	93	1,5
MES 414-9	2	125	99	93	2